

DMX 3-in-1

Splitter, Isolator, Repeater

Design by J. Mack

This project dubbed 'DMX 3-in-1' is an active splitter that distributes a single DMX signal across three outputs. In addition it features full electrical isolation between input and outputs, while any of the three outputs can act independently of the others.

The DMX 3-in-1 splitter/isolator/repeater can be used with all equipment that supports DMX512, and will help to increase its reliability in actual operation. The unit will

also prove useful for quick re-cabling of equipment, because it allows the (physically) shortest link to be created.

An example may help to illustrate the point: let's assume there's DMX equipment at the left-hand as well as the right-hand side of the stage.

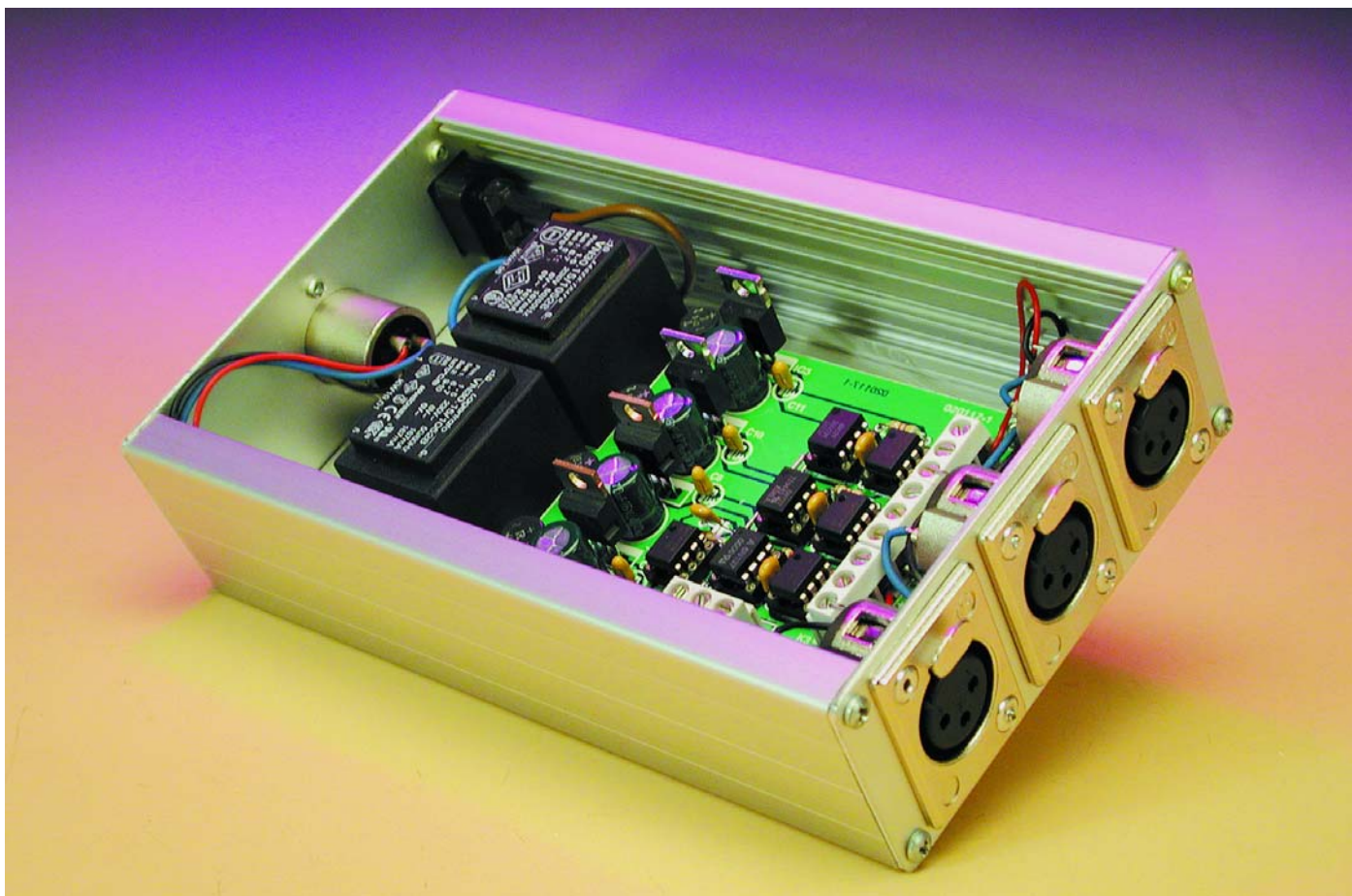

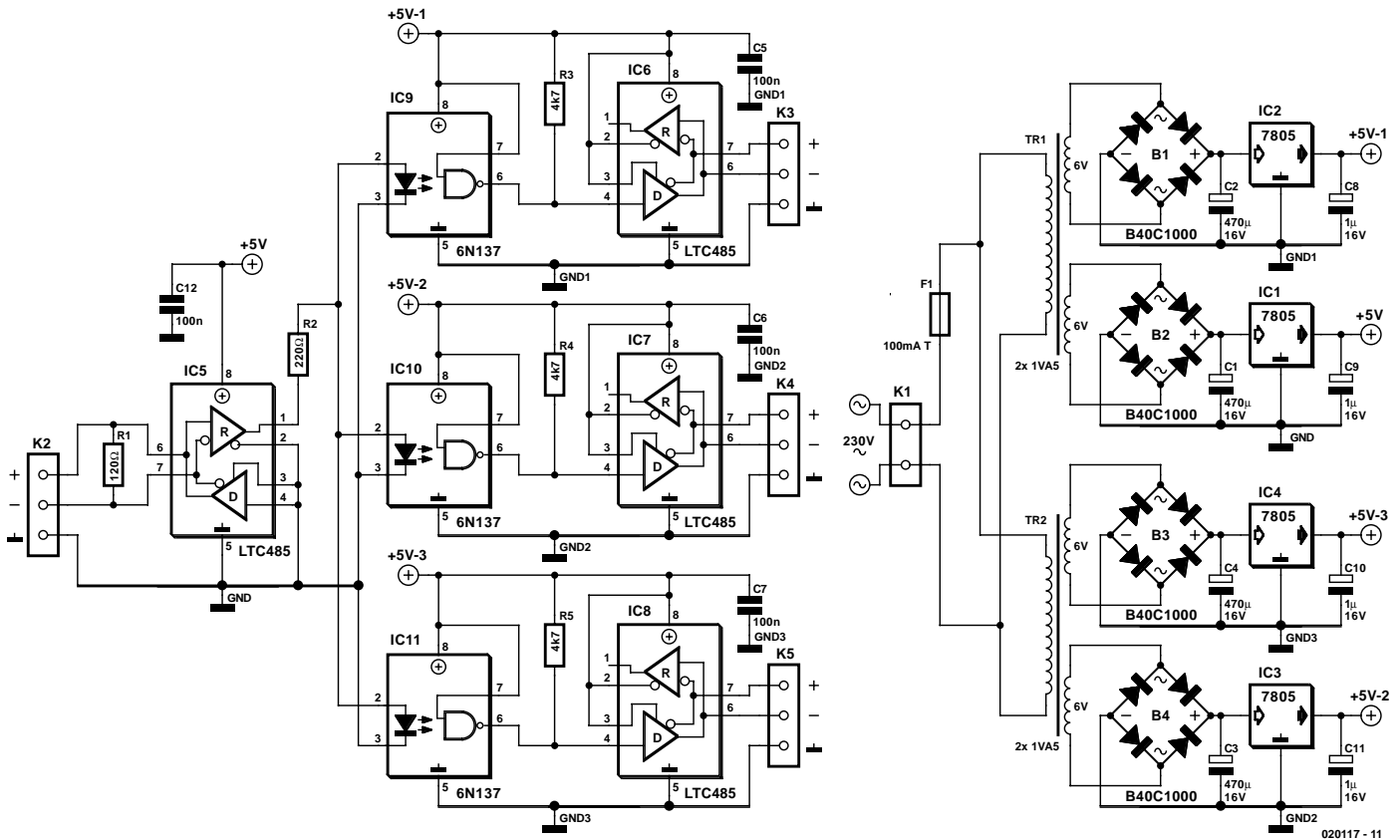

Figure 1. The circuit diagram of the DMX 3-in-1 comprises four electrically isolated subsections.

Without the splitter, it would be awkward to feed one cable to one side only, then take it back all the way to the origin, then on to the other side, and then from equipment to equipment. Arguably, this is not the best solution to distributing DMX signals across equipment.

The DMX splitter makes the cabling job much easier. Only one cable is required at each side, where it is used to interconnect all equipment.

Repetitia Placet

A quick glance at the circuit diagram in **Figure 1** shows that the DMX 3-in-1 consists of three identical sub-circuits. Resistor R1 at the input of the circuit acts as a terminator ('terminating resistance') for the DMX bus, which, as you may know, works in compliance with well established RS485 standards. The DMX signal is first converted to TTL by level converter IC5. The LTC485 from Linear Technology is an interface component that translates RS485 signals into TTL (receiver, R), and vice versa,

TTL into RS485 (driver, D). In this circuit the transmitter section of the chip has been disabled. The datasheets of this interesting chip may be found at www.linear-tech.com/pdf/485ff.pdf

Behind IC5, the signal is split across three identical circuits. High-speed optocouplers type 6N137 guarantee electrical isolation. Resistor R2 limits the current through the LEDs inside the optocouplers. The optocouplers are enabled by means of a High level at pin 7. Pull-up resistors (R3, R4, R5) are required at their outputs which are of the open-collector (OC) variety.

Next, the signal once again meets an LT485. This time, however, only the transmitter (D) is employed. A small difference may be noted with respect to IC5: Because of the inverting action of the optocouplers, the outputs of the LTC485's are transposed to prevent unwanted inversion.

The tripled DMX signal leaves the circuit via connectors K3, K4 and K5. The electrical isolation that exists between the three outputs will prove invaluable when errors occur.

An error on one DMX line will only cause one output to fail instead of the complete unit — the other outputs will continue to operate normally!

The power supply is seen in the right-hand section of the circuit diagram. Because we are dealing with four electrically isolated sub-circuits in the DMX512 path, there is a requirement for four independently operating power supplies. Although this requirement could be fulfilled using a mains supply incorporating special DC/DC converters, the current consumption of the circuit is so low that two 1.5-VA transformers, each having two secondary windings, are probably cheaper and less demanding in respect of board space, albeit less elegant. Each of the four secondaries is followed by a small rectifier bridge feeding a three-pin fixed voltage regulator type 7805.

Construction

The artwork for the printed circuit board (**Figure 2**) shows a dead conventional project when it comes to building it. Ready-made printed circuit boards for the project may be obtained from **The PCBShop** (i.e., they are not available through Elektor's Readers Services). Do not forget to fit all 4 (four) wire links on the

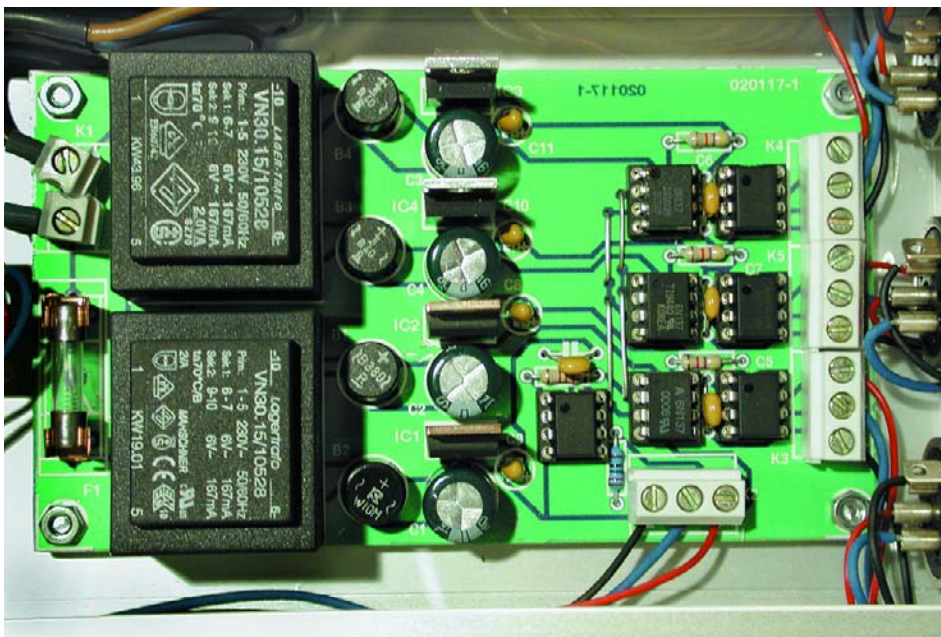
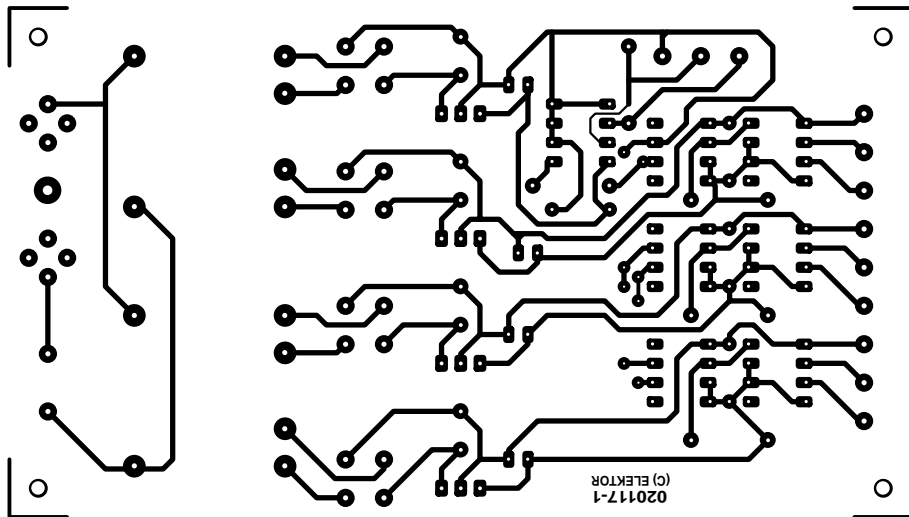
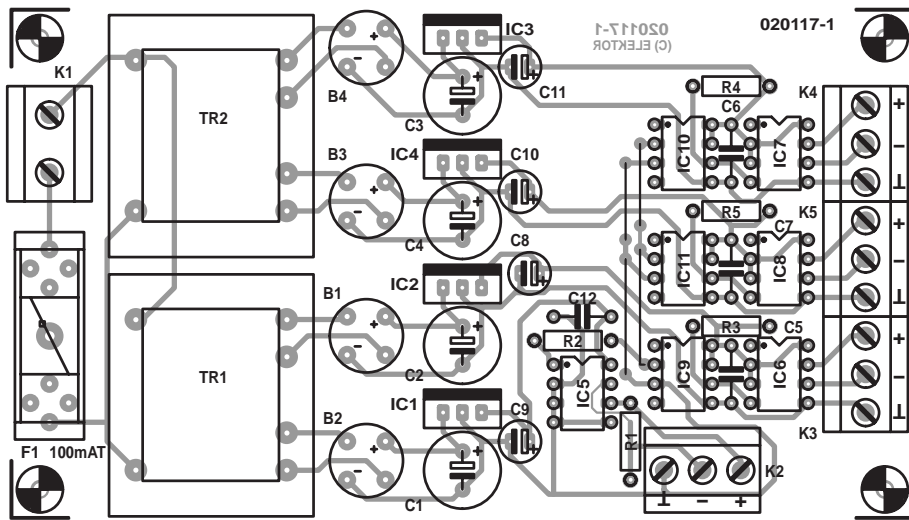

Figure 2. Copper track layout and component mounting plan (board available from The PCBShop).

board and be sure to mount all ICs with the correct orientation. IC sockets are recommended, but not obligatory.

The enclosure that holds the DMX 3-in-1 must be 'stage, bullet and fool-proof' as well as electrically safe, complying with Class-2 electrical isolation requirements. In particular, the distance between mains-carrying parts on the PCB and the metal case should be 6 mm minimum. This rules out the use of 5-mm PCB spacers. The XLR chassis-mount sockets/plugs and the IEC appliance socket are best secured to the case with rivets.

(020117-1)

COMPONENTS LIST

Resistors:

- R1 = 120Ω
- R2 = 220Ω
- R3,R4,R5 = 4kΩ27

Capacitors:

- C1-C4 = 470μF 16V radial
- C5,C6,C7,C12 = 100nF
- C8-C11 = 1μF 16V radial

Semiconductors:

- B1-B4 = B40C1000, round case (40V piv, 1A)
- IC1-IC4 = 7805
- IC5-IC8 = LTC485CN8 or SN75176BP
- IC9,IC19,IC11 = 6NI37

Miscellaneous :

- F1 = fuse holder, PCB mount, with fuse 100mA(T) (slow)
 - K1 = 2-way PCB terminal block, lead pitch 7.5mm
 - K2-K5 = 3- way PCB terminal block, lead pitch 5mm
 - Tr1,Tr2 = mains transformer, 2x6 V secondaries, 1.5VA or 2 VA
 - 1 off IEC mains appliance socket
 - 3 off XLR socket (female), 3-way, chassis mount, 180 degrees
 - 1 off XLR plug (male), 3-way, chassis mount, 180 degrees
- PCB, available from **The PCBShop**