

Service
Service
Service

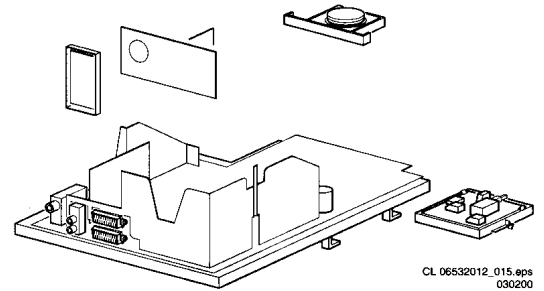

CL 06532012_015.eps
030200

Service Manual

Contents	Page	Contents	Page
1. Technical Specifications	2	8. Alignments	53
2. Safety- and maintenance instructions, warnings and notes.	4	9. Circuit description and list of abbreviations	58
3. Directions for use	6	10. Spareparts list	68
4. Mechanical instructions	13		70
5. Faultfinding and repair tips	15		
6. <i>Faultfinding trees</i>			
Supply voltage diagram	23		
Blockdiagram	24-25		
Testpointsoverview	26		
Wiring diagram	27		
7. <i>Electrical diagram's en PWB's</i>	<i>Diagram PWB</i>		
Power supply (Diagram A1)	28	35-37	
Horizontal deflection (Diagram A2)	29	35-37	
Vertical deflection (Diagram A3)	30	35-37	
SSP Tuner (Diagram A4)	31	35-37	
SSP SCART (Diagram A5)	32	35-37	
Audio (Diagram A6)	33	35-37	
Front control/Rotation/Headphone (Diagram A7)	34	35-37	
CRT panel (Diagram B)	38	39	
IF & Sync. (Diagram C1)	40	47-48	
Video processing (Diagram C2)	41	47-48	
Video features (Diagram C3)	42	47-48	
Diversity tables (SSB)	43		
Micro controller (Diagram C4)	44	47-48	
Memory (Diagram C5)	46	47-48	
Audio processing (1) (Diagram C6)	45	47-48	
Audio processing (2) (Diagram C7)	46	47-48	
SSB connector (Diagram C8)	47	47-48	
Side I/O panel (Diagram D)	49	50	
Top control panel (Diagram E)	51	51	
Front interface panel (Diagram J)	52	52	

©Copyright reserved 2000 Philips Consumer Electronics B.V. Eindhoven, The Netherlands. All rights reserved. No part of this publication may be reproduced, stored in a retrieval system or transmitted, in any form or by any means, electronic, mechanical, photocopying, or otherwise without the prior permission of Philips.



6. Blockdiagram, supply diagram and testpointoverviews.

Supply voltage diagram

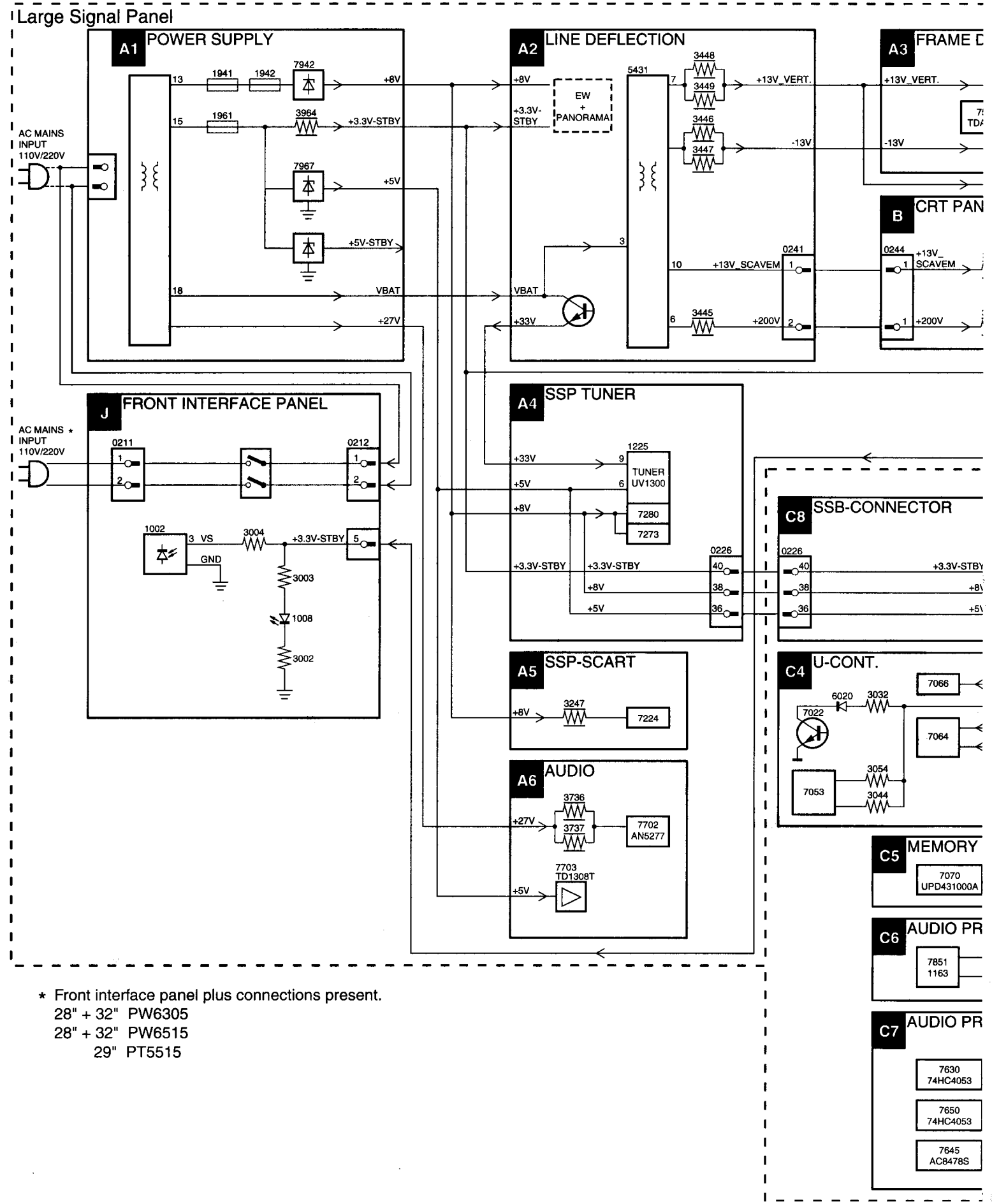

* Front interface panel plus connections present.
 28" + 32" PW6305
 28" + 32" PW6515
 29" PT5515

Small Signal Panel

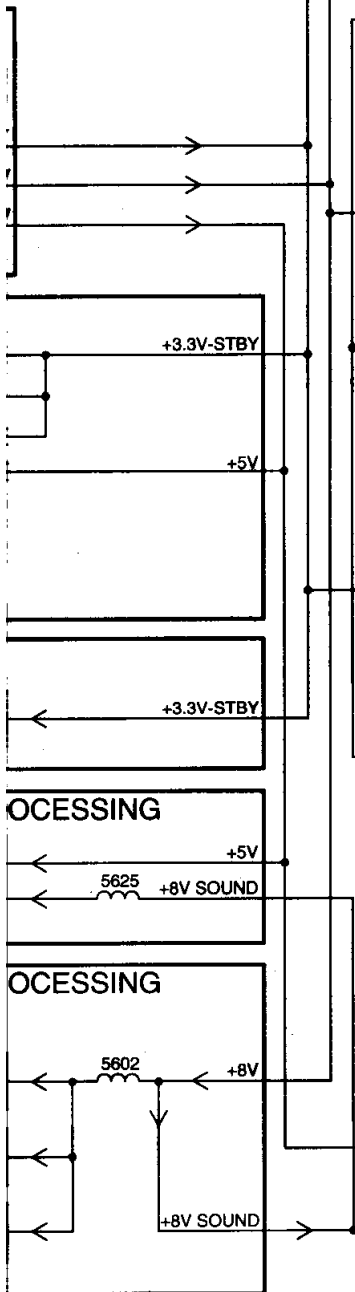
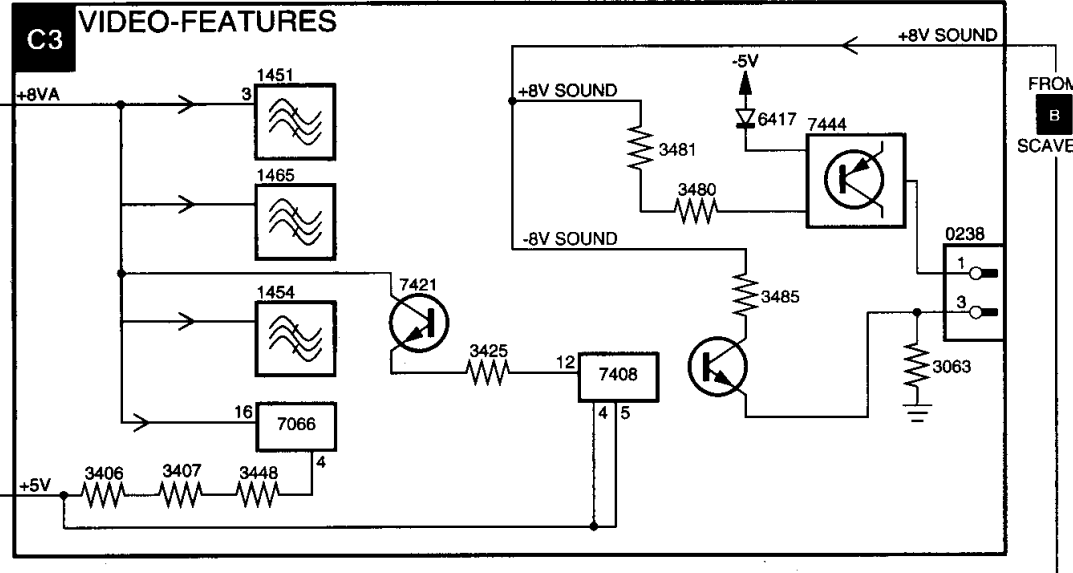
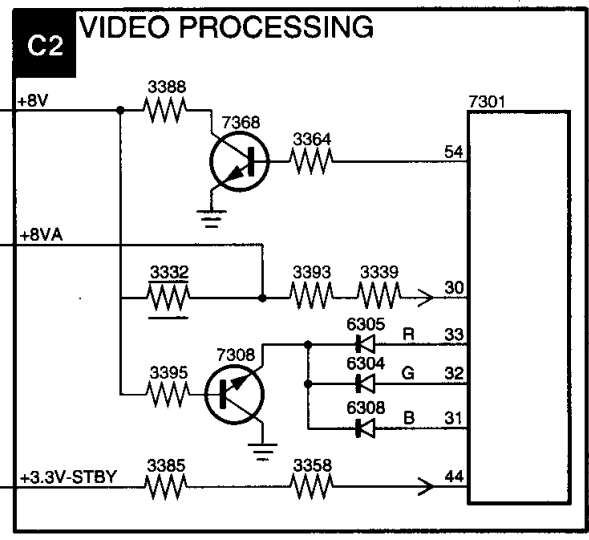
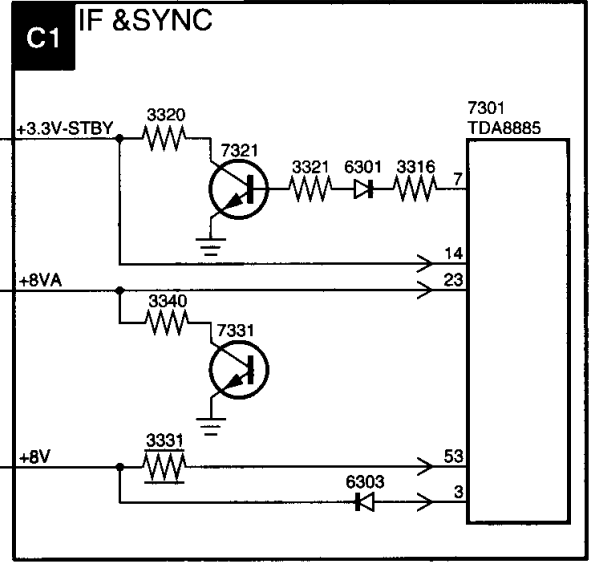
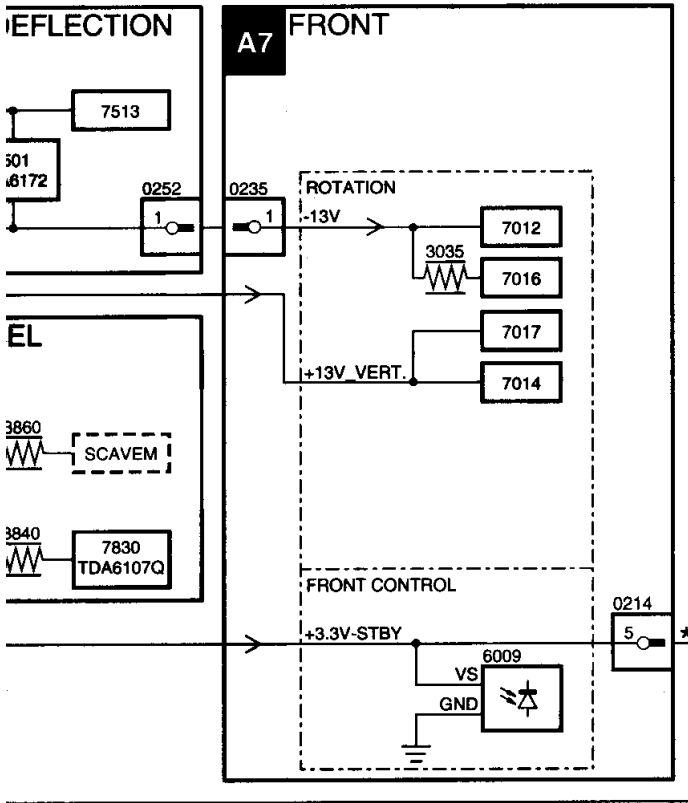

Blockdiagram

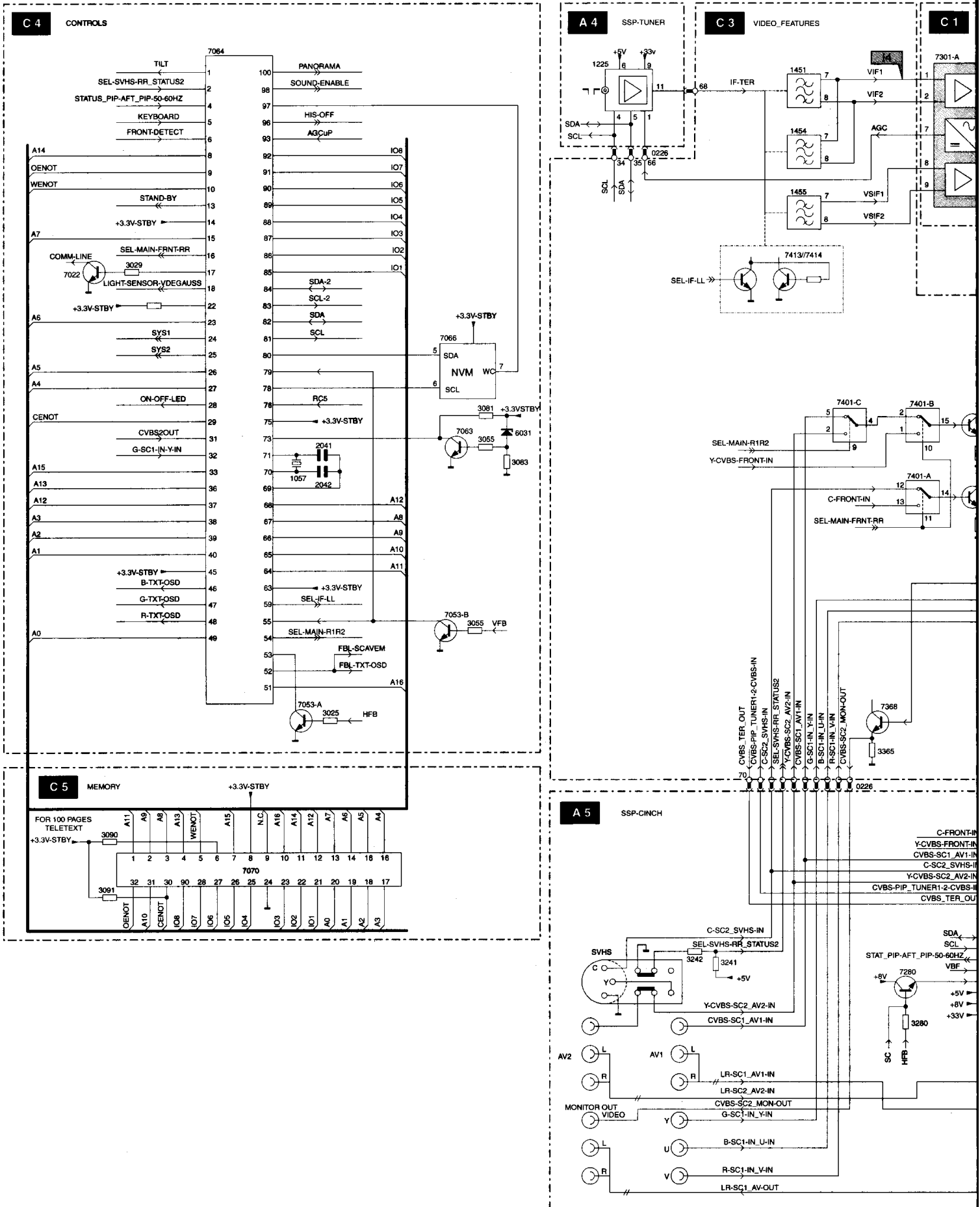

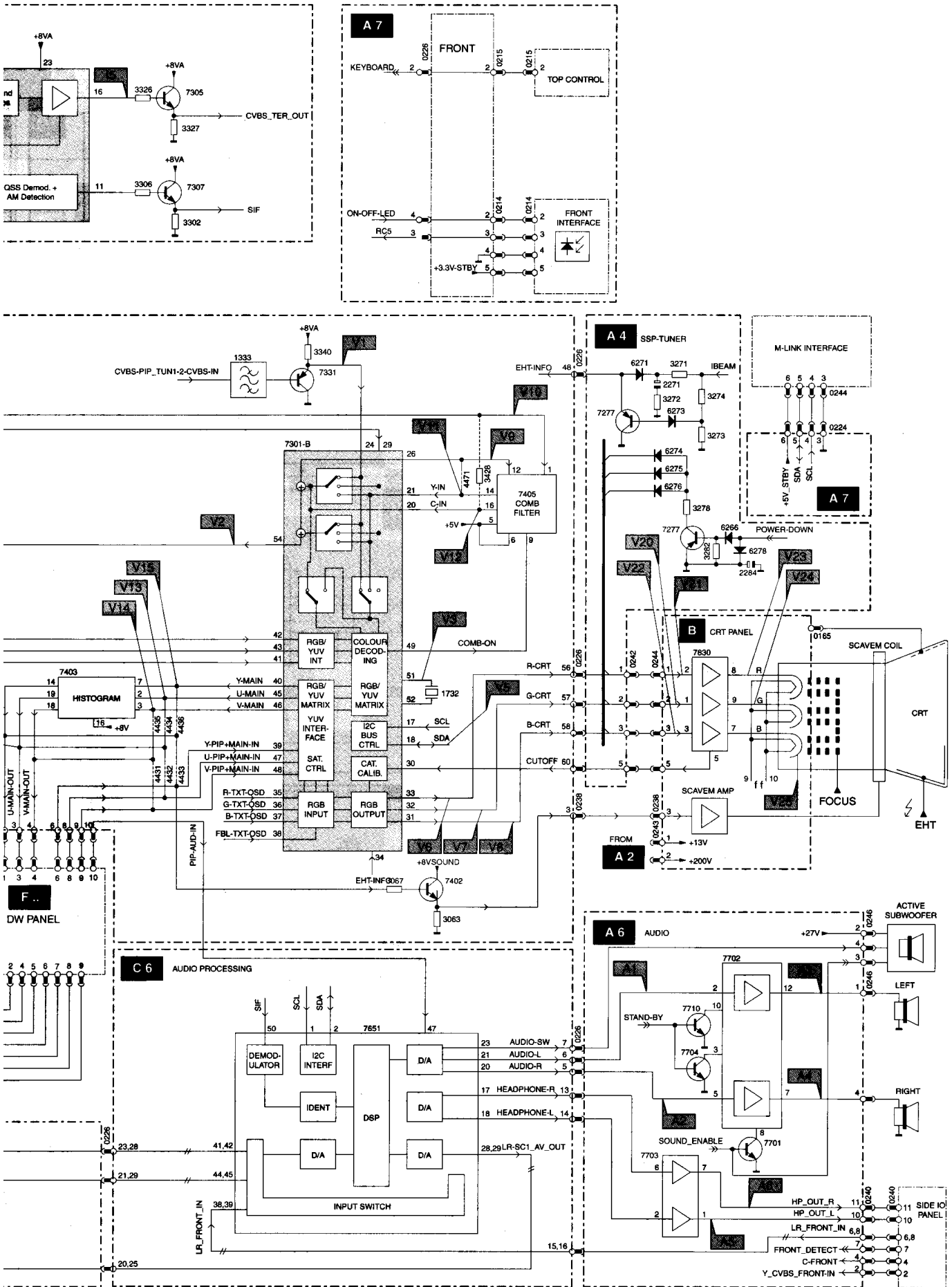

Blockdiagram

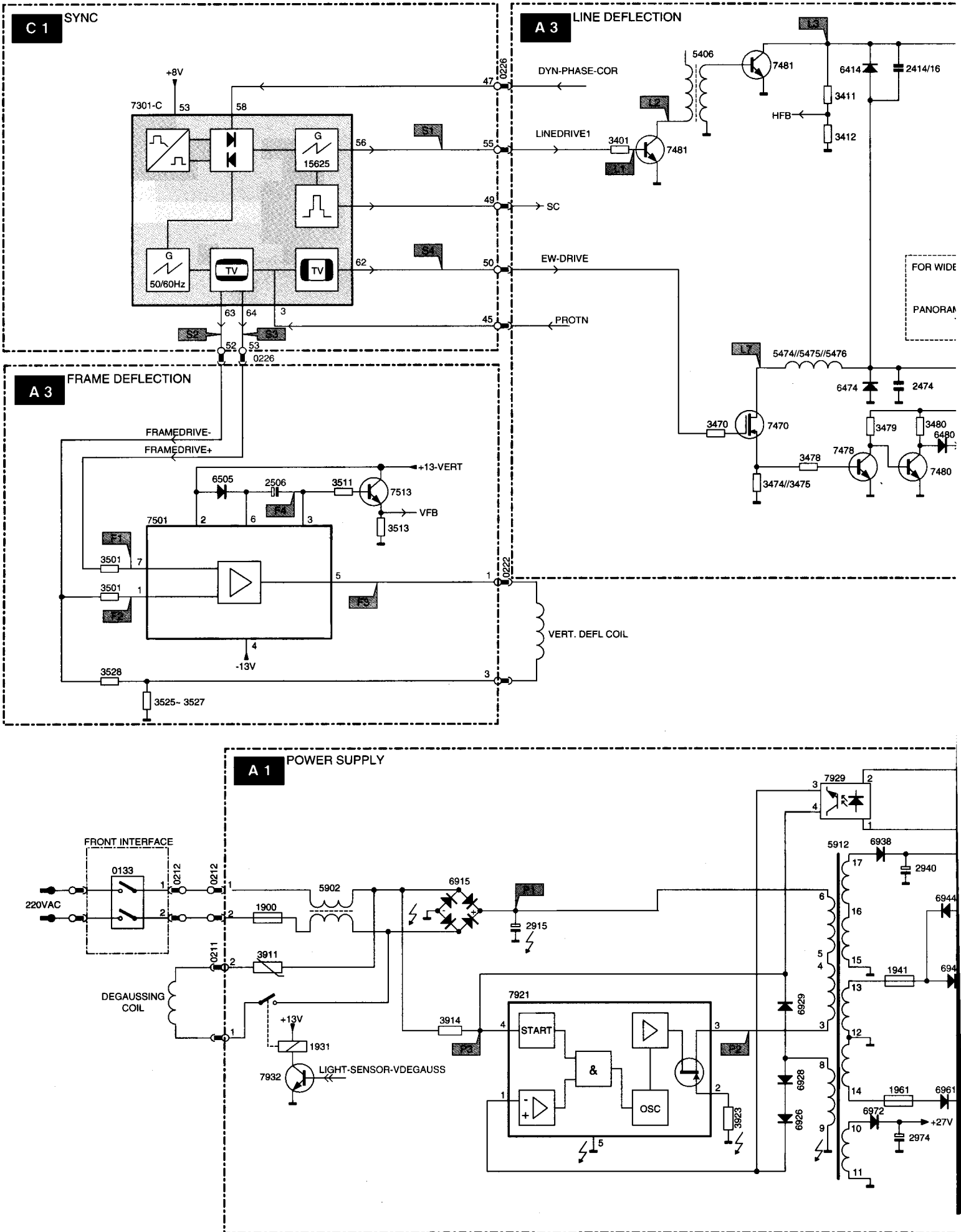

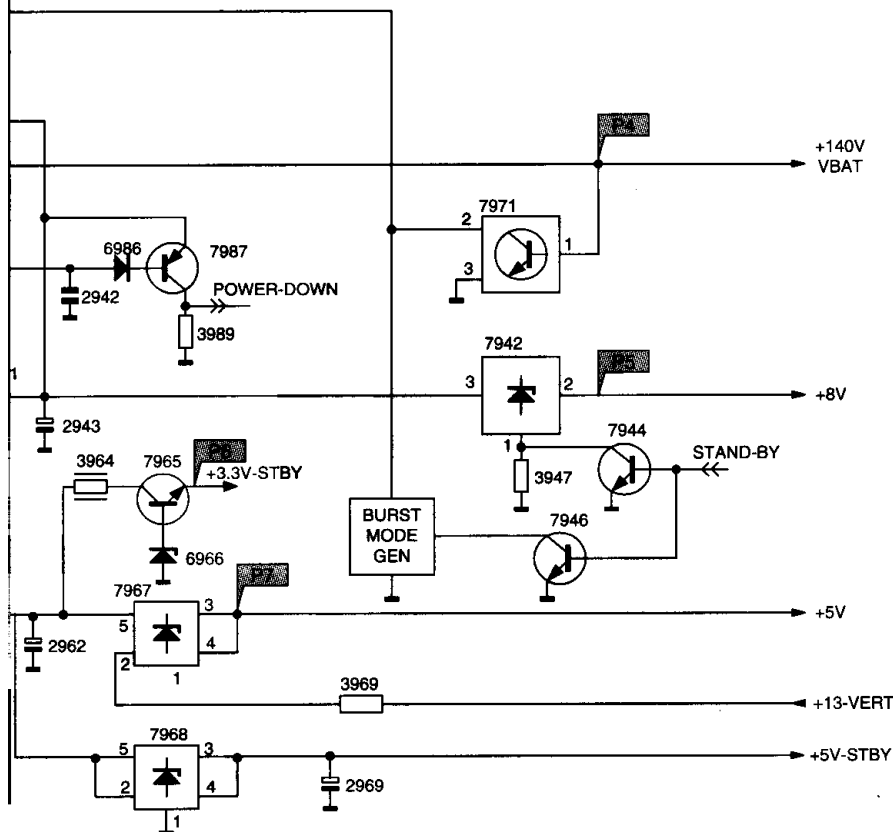
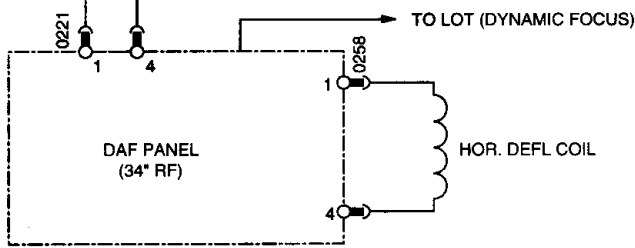
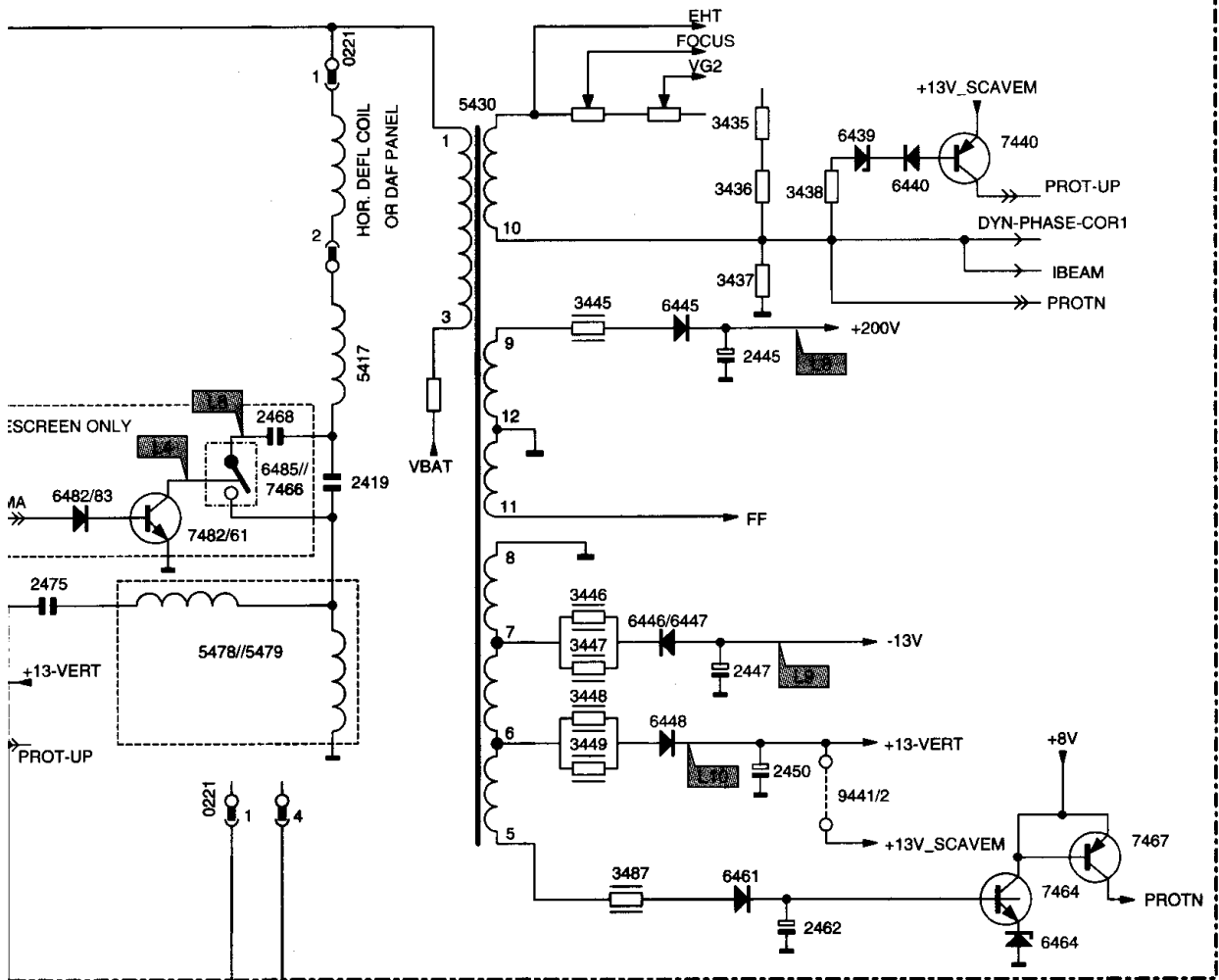

7. Schematics and PWB's

Power supply

A1 POWER SUPPLY

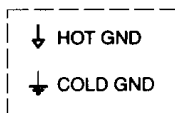
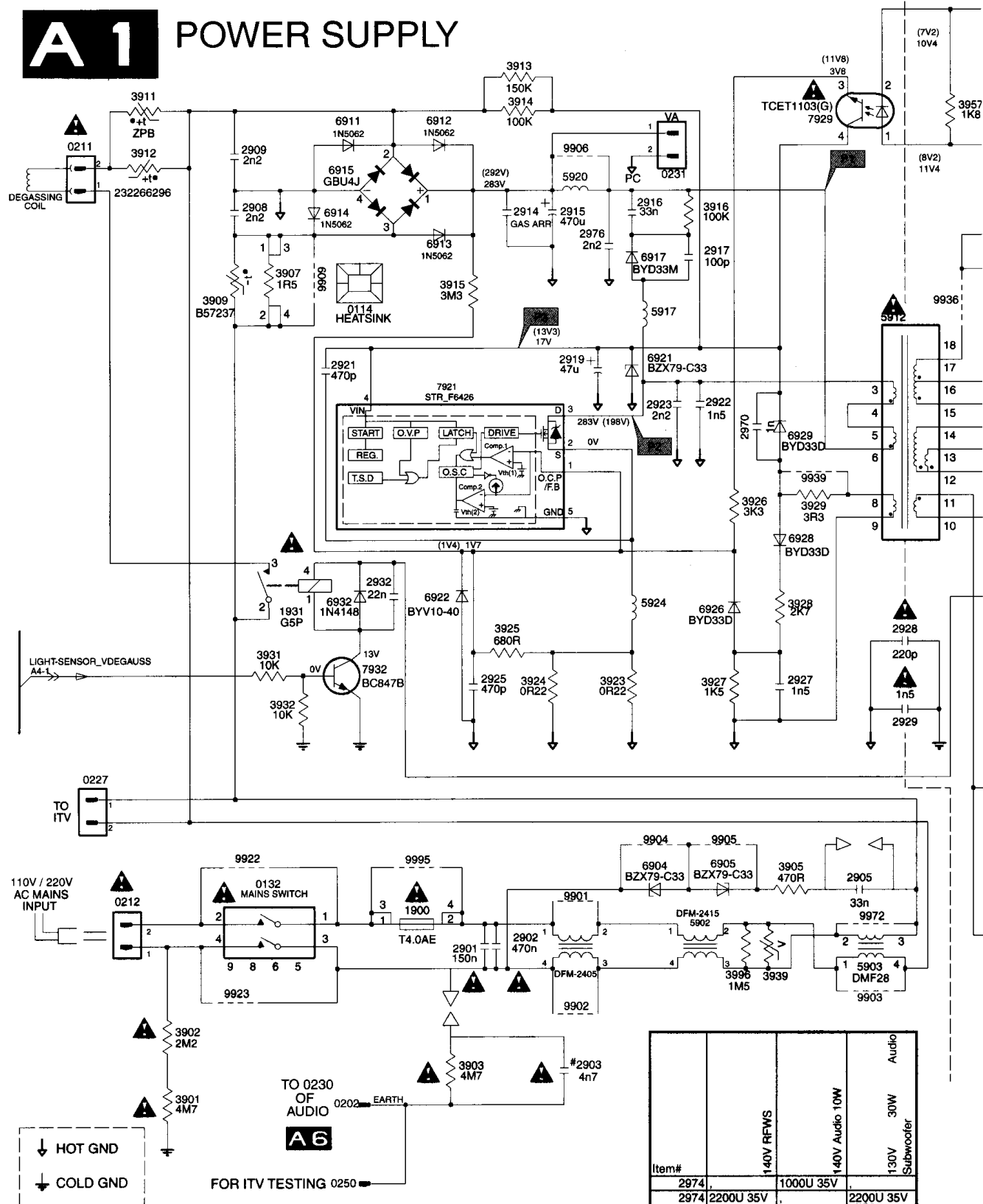

TO 0230 OF AUDIO 0202 EARTH
A6
 FOR ITV TESTING 0250

Item#	140V RFWS	140V Audio 10W	130V Subwoofer	Audio
2974		1000U 35V		
2974	2200U 35V		2200U 35V	
3901		4M7		
3902		2M2		
7971	SE140N	SE140N		
7971			SE130N	
9922	jumper		jumper	
9923	jumper		jumper	

0114 C3	3969 F11
0119 E9	3970 E10
0132 F3	3971 B11
0202 G3	3977 B10
0206 A8	3986 B10
0211 A2	3987 A10
0212 F2	3989 B11
0227 E2	3991 A10
0231 B5	3992 A10
0250 H3	3993 A11
1900 F4	3994 B11
1931 D3	3995 A11
1941 C8	3996 G6
1961 E8	3997 G8
2901 G4	4903 C11
2902 F4	5902 F5
2903 G5	5903 G7
2905 F6	5912 C7
2908 B3	5917 B5
2909 A3	5920 B5
2914 B4	5924 D5
2915 B5	5936 B8
2916 B5	5939 C11
2917 B6	5941 C8
2919 C5	5961 E8
2921 C3	5971 F7
2922 C6	6904 F5
2923 C5	6905 F6
2925 E4	6911 A3
2927 E6	6912 A4
2928 E7	6913 B4
2929 E7	6914 B3
2932 D3	6915 B3
2936 B8	6917 B5
2938 B8	6921 C5
2939 B9	6922 D4
2940 B9	6926 D6
2941 C8	6928 D6
2942 D8	6929 C6
2943 D9	6932 D3
2944 C12	6938 B8
2945 C11	6941 C8
2952 D10	6942 D8
2953 D10	6953 D10
2955 D9	6954 E10
2961 E9	6955 E10
2962 E9	6961 E9
2963 E8	6966 F11
2964 F8	6971 F8
2966 E12	6972 F8
2967 F10	6973 D11
2968 G10	6977 G8
2969 G10	6986 B10
2970 C6	6991 A10
2974 F8	7921 C4
2975 F9	7922 F11
2976 B5	7929 A6
2977 G8	7932 E3
3901 H2	7942 C9
3902 G2	7944 C11
3903 G4	7946 E12
3905 F6	7948 D11
3907 B3	7950 G11
3909 B2	7951 D11
3911 A2	7953 E10
3912 B2	7955 E9
3913 A4	7965 E11
3914 A4	7966 E10
3915 B4	7967 F10
3916 B6	7968 G9
3917 F10	7971 C11
3923 E5	7987 B11
3924 E4	7990 A11
3925 D4	7991 A12
3926 D6	9901 F5
3927 E6	9902 G5
3928 D6	9903 G7
3929 D6	9904 F5
3931 E3	9905 F6
3932 E3	9906 B5
3939 G6	9909 B3
3942 C9	9920 F10
3943 C10	9921 F11
3944 D11	9922 F3
3946 D12	9923 G3
3947 D9	9936 B7
3948 D11	9937 B7
3951 D11	9938 B8
3952 D10	9939 D6
3953 D10	9941 C8
3954 D10	9942 C8
3955 D10	9961 E8
3957 A7	9964 E9
3958 B7	9967 F11
3959 F11	9971 F8
3960 G11	9972 F7
3961 F12	9989 B8
3962 F10	9993 C11
3963 F8	9995 F4
3964 E10	9997 E9
3965 F11	
3966 F9	
3967 F10	
3968 G10	

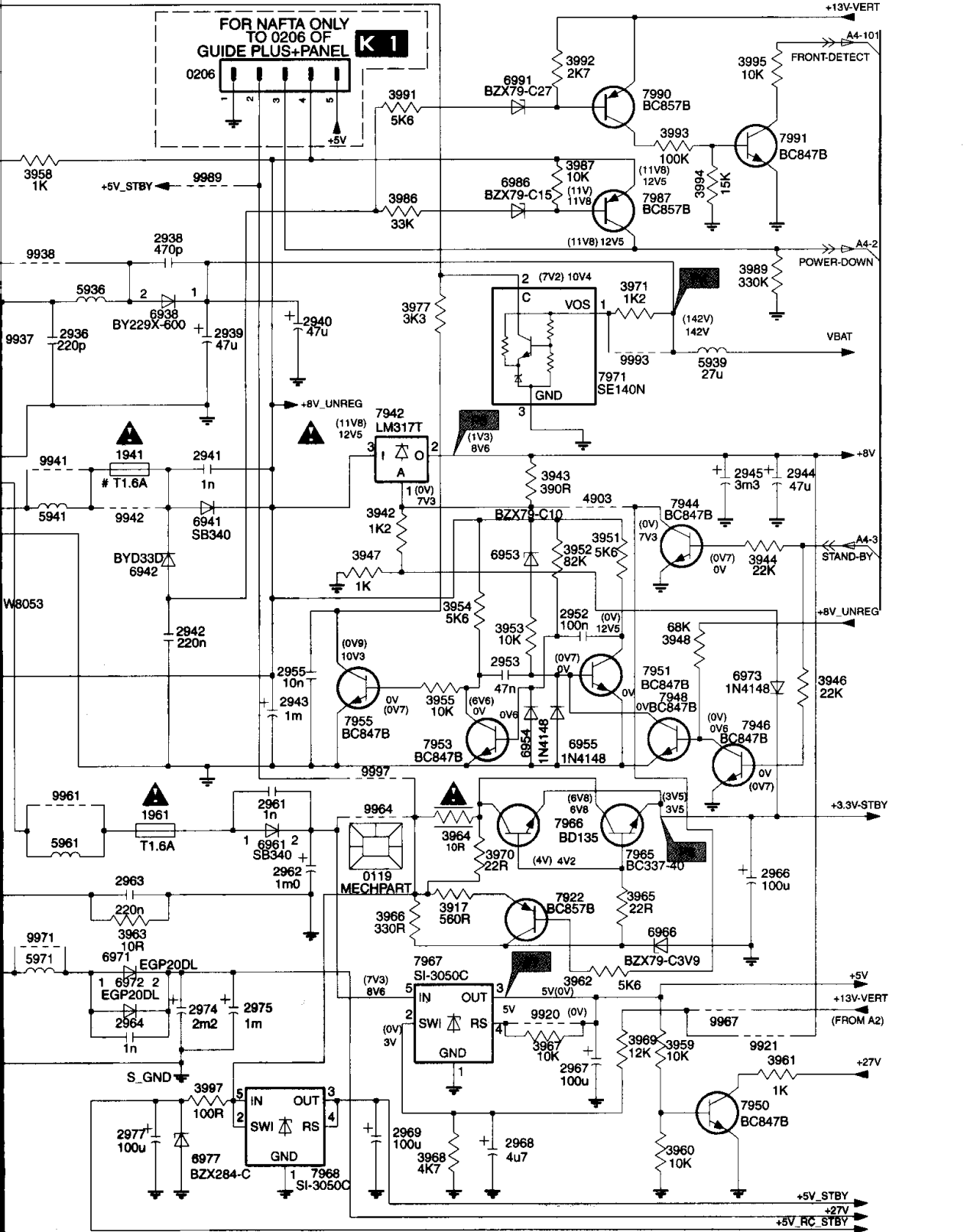
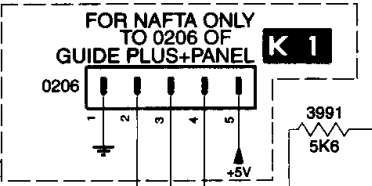

A
B
C
D
E
F
G
H

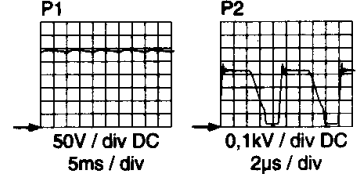

- P3 17V DC
- P4 140V DC
- P5 8V
- P6 3V3 DC
- P7 5V DC

Line deflection

A2

LINE DEFLECTION

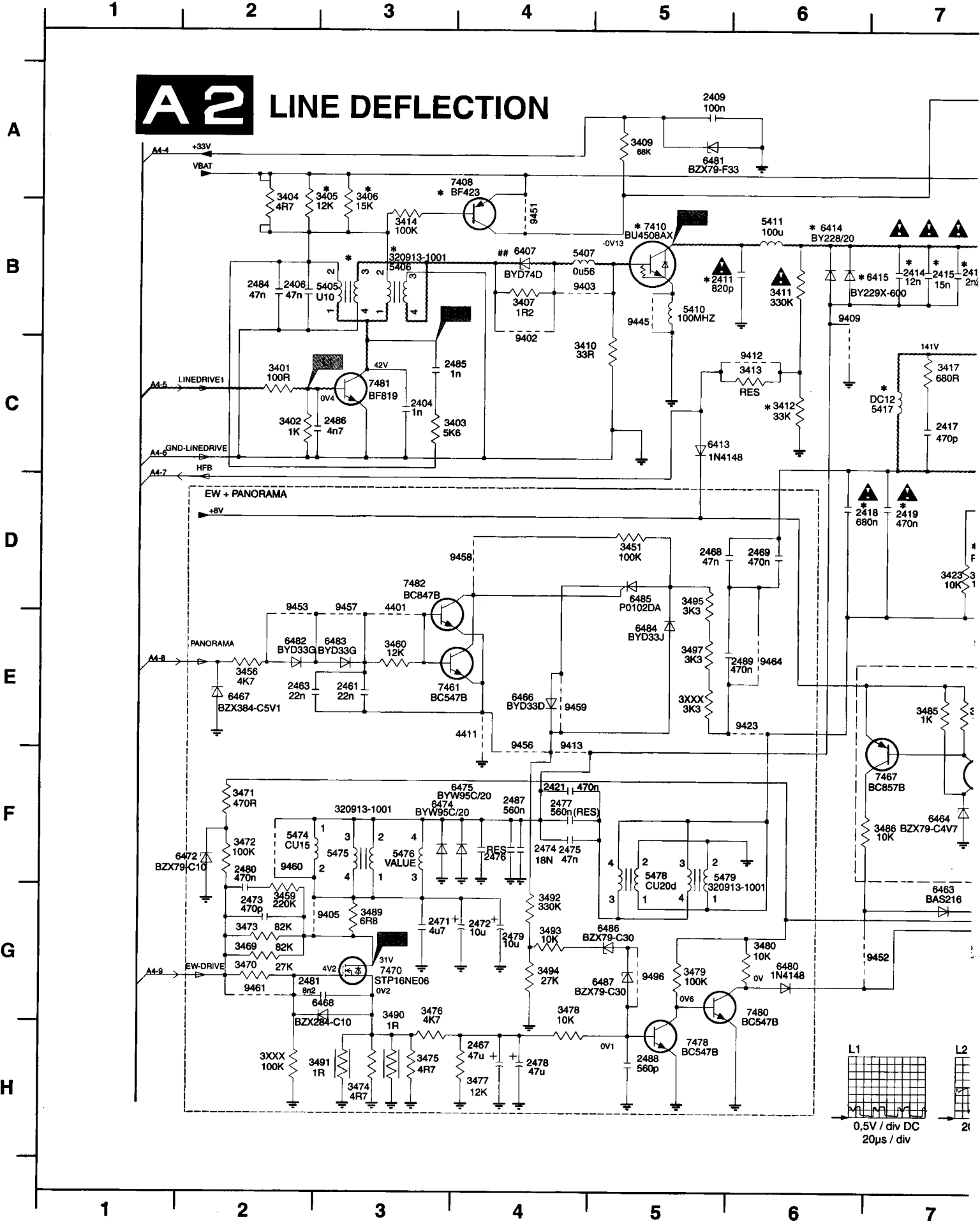

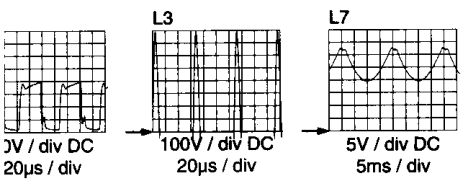
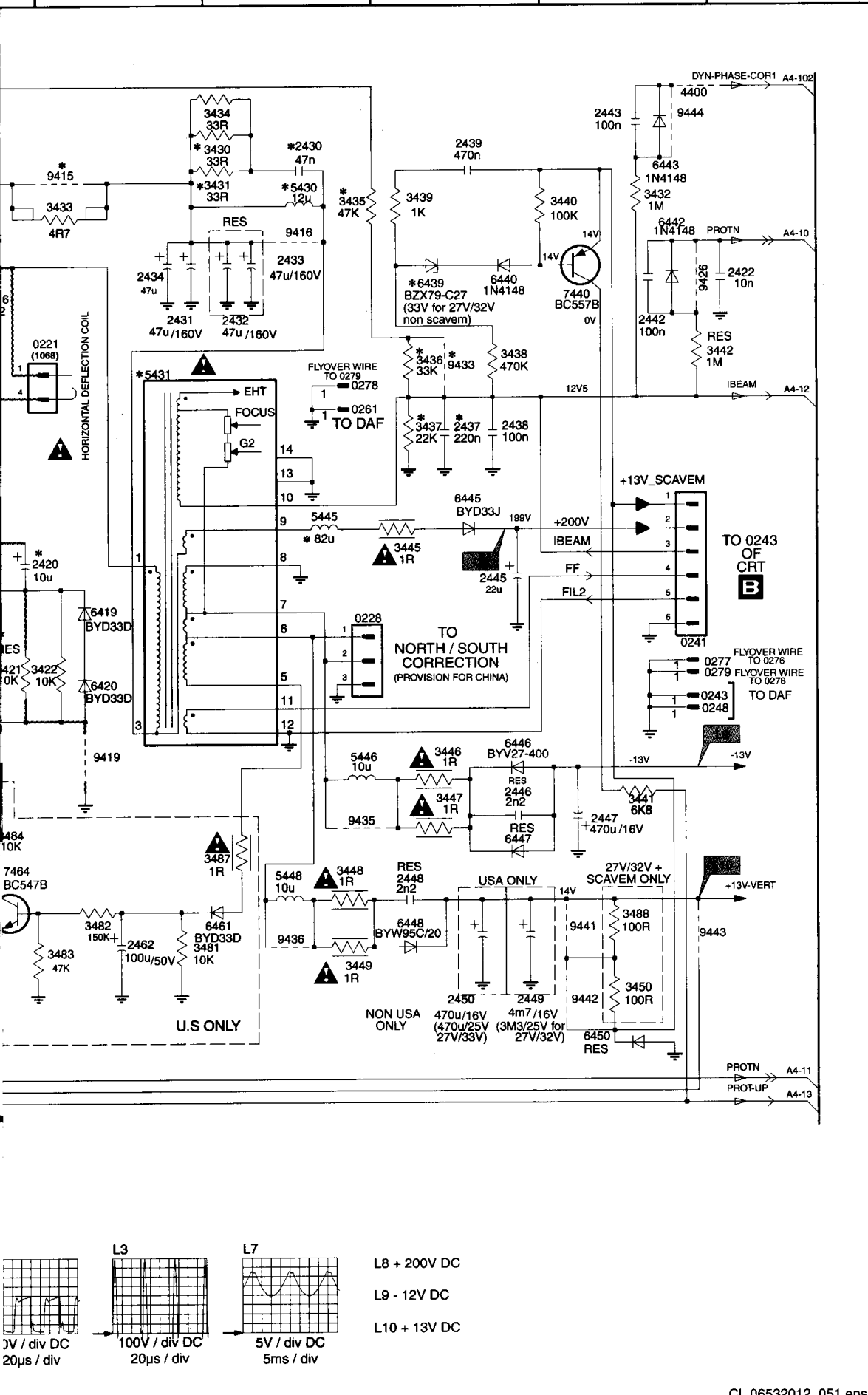

L8 + 200V DC
 L9 - 12V DC
 L10 + 13V DC

0221 B7	3469 G2	9423 E6
0228 D9	3470 G2	9426 B11
0241 D11	3471 F2	9431 B10
0243 D12	3472 F2	9435 E9
0248 D12	3473 G2	9436 F9
0261 C10	3474 H3	9441 F11
0277 D12	3475 H3	9442 F11
0278 C10	3476 G3	9443 F12
0279 D12	3477 H4	9444 A11
2404 C3	3478 G4	9445 B5
2406 B2	3479 G5	9451 B4
2409 A5	3480 G6	9452 G7
2411 B5	3481 F9	9453 E2
2414 B7	3482 F8	9456 F4
2415 B7	3483 F8	9457 E3
2416 B7	3484 E7	9458 D4
2417 C7	3485 E7	9459 E4
2418 D6	3486 F7	9460 F2
2419 D7	3487 E9	9461 G2
2420 D8	3488 F11	9464 E6
2421 F4	3489 G3	9496 G5
2422 B12	3490 G3	
2430 A9	3491 H3	
2431 B8	3492 G4	
2432 B9	3493 G4	
2433 B9	3494 G4	
2434 B8	3495 D5	
2437 C10	3497 E5	
2438 C10	3498 H2	
2439 A10	3XXX E5	
2442 B11	4400 A11	
2443 A11	4401 E3	
2445 D10	4411 E4	
2446 E10	5405 B3	
2447 E11	5406 B3	
2448 E10	5407 B4	
2449 F10	5410 B5	
2450 F10	5411 B6	
2461 E3	5417 C7	
2462 F8	5430 A9	
2463 E2	5431 B8	
2467 H4	5435 C9	
2468 D5	5446 E9	
2469 D6	5448 E9	
2471 G3	5474 F2	
2472 G4	5475 F3	
2473 G2	5476 F3	
2474 F4	5478 F5	
2475 F4	5479 F5	
2476 F4	6407 B4	
2477 F4	6413 C5	
2478 H4	6414 B6	
2479 G4	6415 B7	
2480 F2	6419 D8	
2481 G2	6420 D8	
2484 B2	6439 B10	
2485 C3	6440 B10	
2486 C3	6442 B11	
2487 F4	6443 A11	
2488 H5	6445 C10	
2489 E6	6446 E10	
3401 C2	6447 E10	
3402 C2	6448 F10	
3403 C3	6450 F11	
3404 A2	6461 F9	
3405 A3	6463 F7	
3406 A3	6464 F7	
3407 B4	6466 E4	
3409 A5	6467 E2	
3410 C4	6468 G3	
3411 B6	6472 F2	
3412 C6	6474 F3	
3413 C6	6475 F4	
3414 B3	6480 G6	
3417 C7	6481 A5	
3421 D7	6482 E2	
3422 D8	6483 E3	
3423 D7	6484 E5	
3430 A9	6485 D5	
3431 A9	6486 G5	
3432 A11	6487 G5	
3433 A8	7408 A3	
3434 A9	7410 B5	
3435 A9	7440 B11	
3436 B10	7461 E3	
3437 C10	7464 E7	
3438 B10	7467 F7	
3439 A10	7470 G3	
3440 A11	7478 H5	
3441 E11	7480 G6	
3442 B12	7481 C3	
3445 D10	7482 D3	
3446 E10	9402 C4	
3447 E10	9403 B4	
3448 E9	9405 G3	
3449 F9	9409 B6	
3450 F11	9412 C6	
3451 D5	9413 F4	
3456 E2	9415 A8	
3459 G2	9416 B9	
3460 E3	9419 E8	

Frame

deflection

4 5 6 7 8 9 10

CTION

A
B
C
D
E
F
G
H

- 0222 D9
- 0232 B9
- 0252 G9
- 2501 E6
- 2502 D5
- 2503 D5
- 2505 C6
- 2506 B6
- 2521 D7
- 2522 D7
- 2523 E6
- 2524 E8
- 2525 C7
- 2531 B4
- 2532 F9
- 2533 D5
- 2534 E6
- 3501 E5
- 3502 D5
- 3503 C5
- 3504 C5
- 3511 C7
- 3512 C8
- 3513 C9
- 3521 D7
- 3522 D8
- 3523 D8
- 3524 E8
- 3525 F8
- 3526 F7
- 3527 F7
- 3528 E7
- 3529 F7
- 3530 F8
- 4502 D5
- 4503 E6
- 5521 D7
- 5523 D8
- 5524 E8
- 6505 B6
- 6511 C7
- 6512 C8
- 6522 D7
- 7501 C6
- 7513 C8

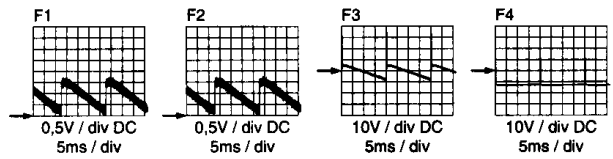
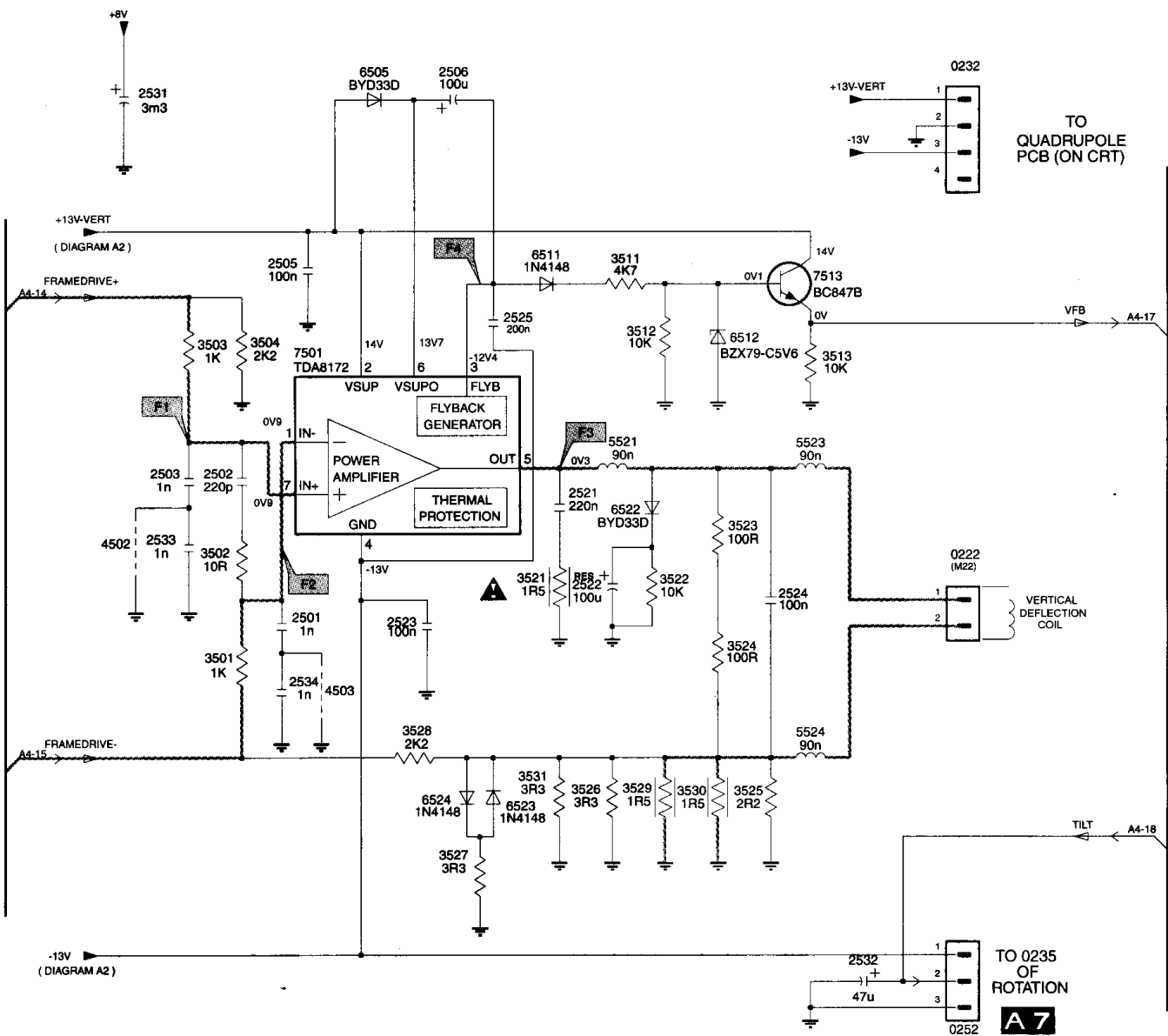

4 5 6 7 8 9 10

SSP-Tuner

A 4 SSP-TUNER

TO 0226
OF SSB-CONNECTOR
C6

0226
80 PINS

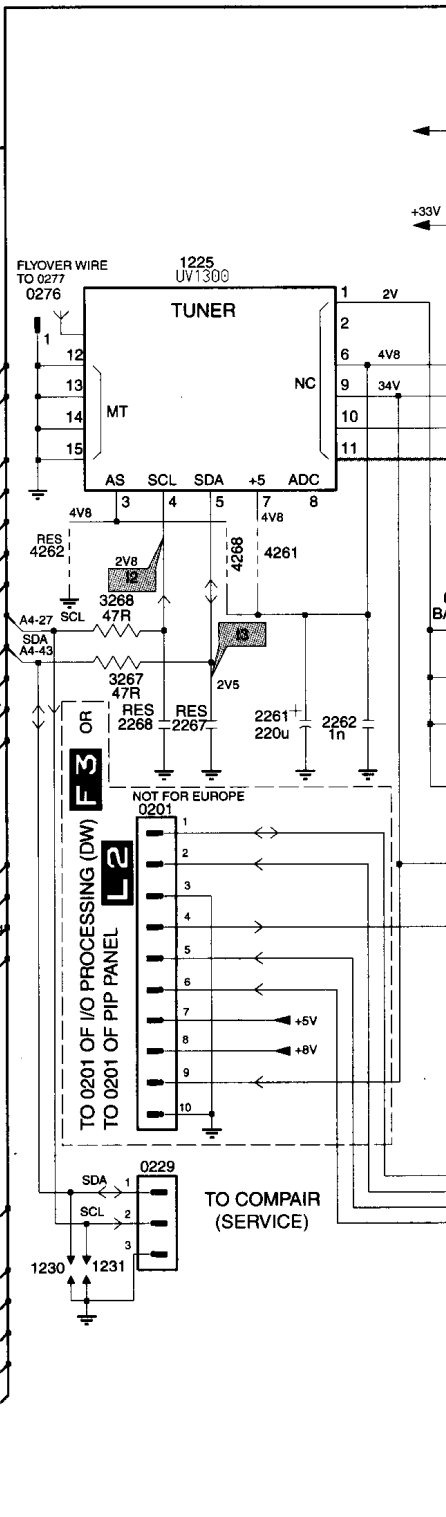
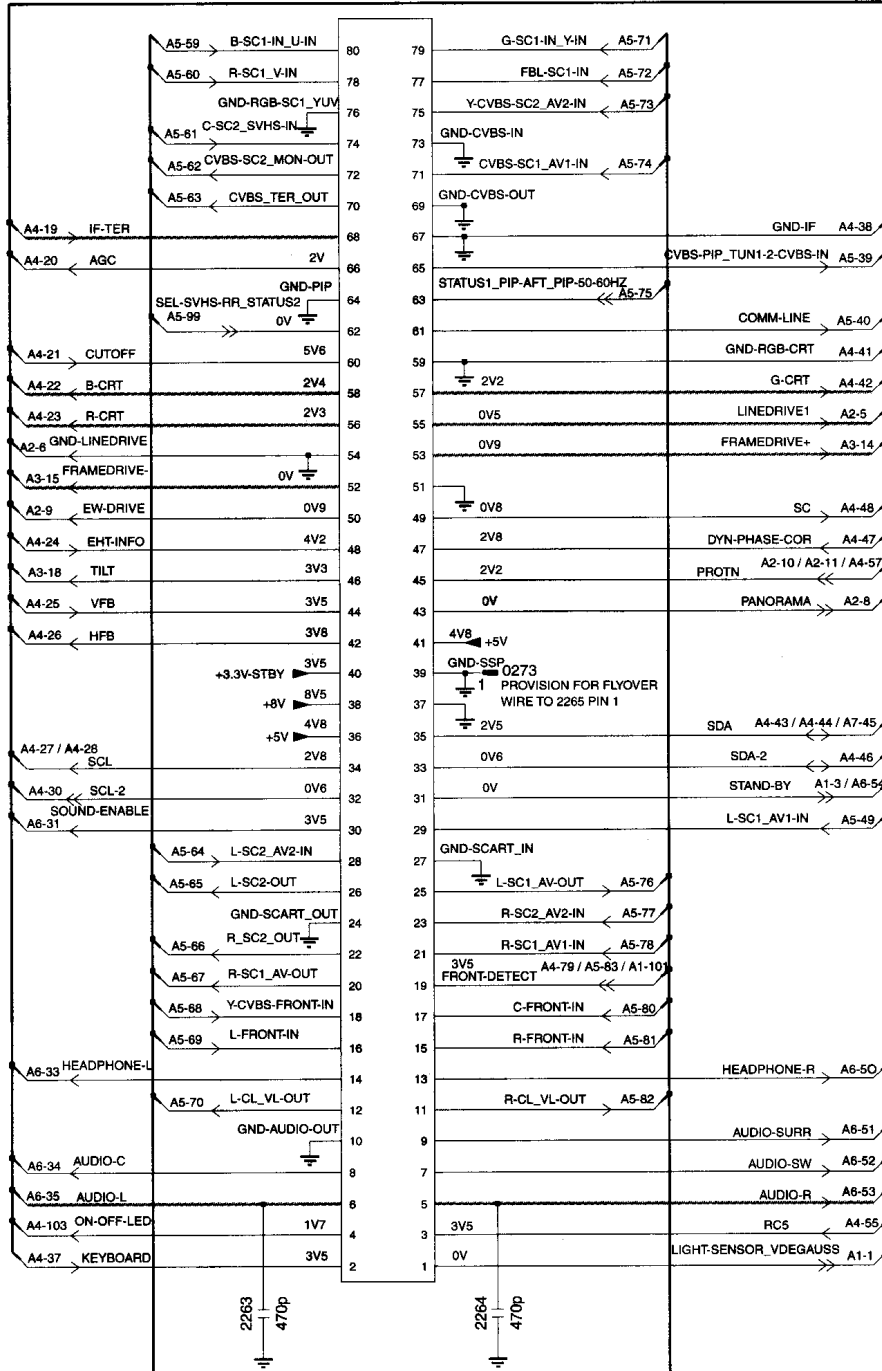

A
B
C
D
E
F
G
H

1 2 3 4 5 6 7

0201 E6
 0226 A3
 0229 F6
 0239 D12
 0242 A12
 0272 E8
 0273 E4
 0276 B5
 1225 B6
 1230 G5
 1231 G6
 2261 D6
 2262 D7
 2263 H2
 2264 H3
 2265 E7
 2266 E8
 2267 D6
 2268 D6
 2271 D10
 2276 E11
 2280 C11
 2281 C11
 2282 C10
 2284 B12
 2286 C8
 2287 C9
 3220 C10
 3255 A11
 3256 A11
 3257 B11
 3263 C8
 3264 D7
 3267 D6
 3268 D6
 3271 D10
 3272 D10
 3273 E10
 3274 D10
 3276 E11
 3277 D11
 3278 B10
 3280 C11
 3281 D10
 3282 B11
 3283 E9
 3284 C8
 3285 D8
 3287 C9
 4218 B10
 4226 C10
 4261 C7
 4262 C5
 4263 D10
 4264 D10
 4267 C10
 4268 C6
 4271 B10
 4272 B11
 5261 B8
 5262 A8
 5263 D8
 6264 D7
 6265 D8
 6266 B11
 6271 D9
 6272 B9
 6273 E10
 6274 B10
 6275 B10
 6276 B10
 6278 B11
 6279 D9
 6280 D8
 7273 E9
 7276 D11
 7277 B11
 7280 C11
 9261 F10
 9262 F11

A

B

C

D

E

F

G

H

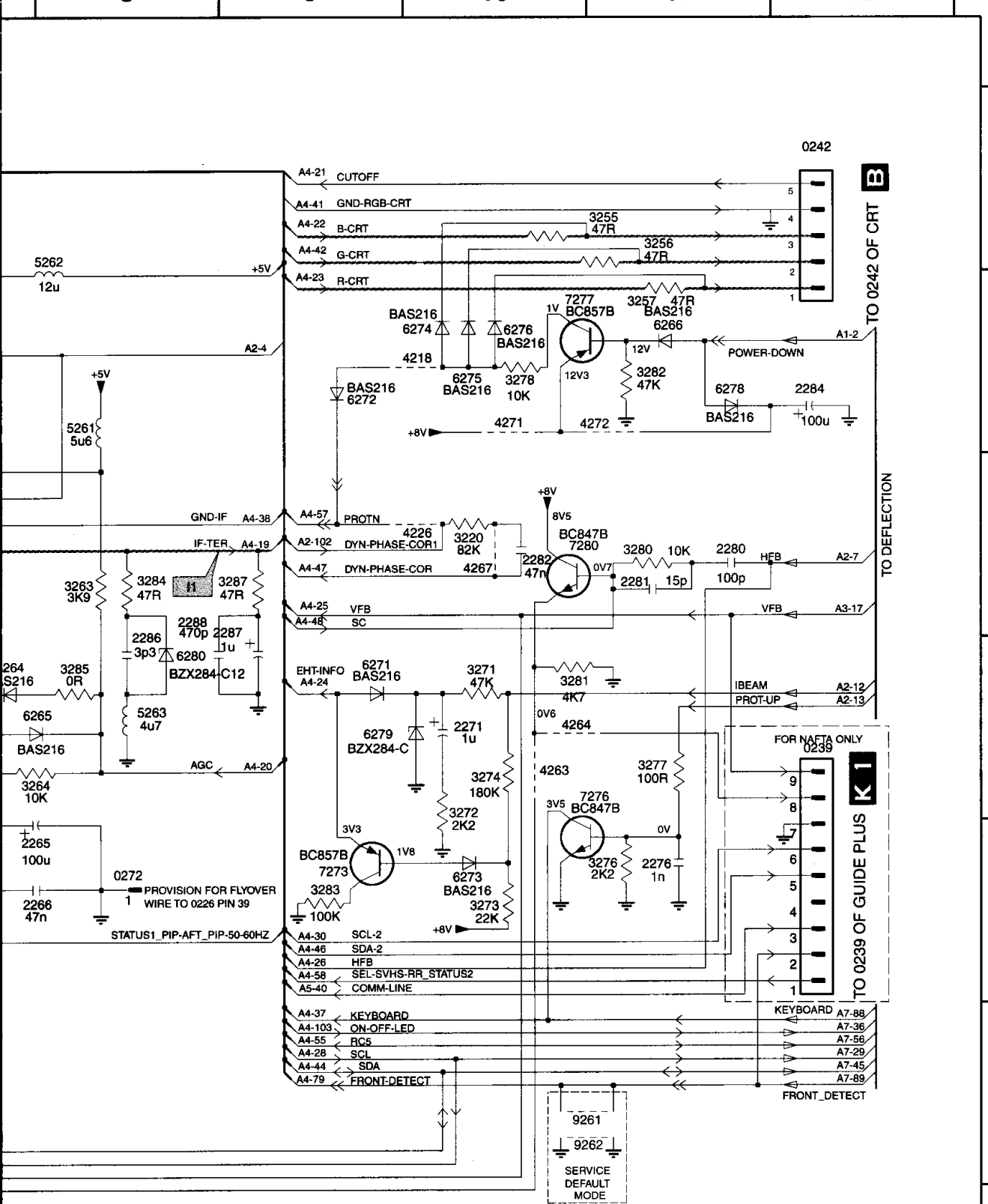

B

K

TO DEFLECTION

TO 0239 OF GUIDE PLUS K1

TO 0242 OF CRT

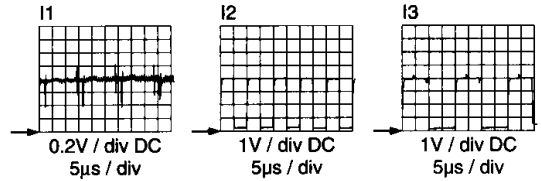

SSP-SCART

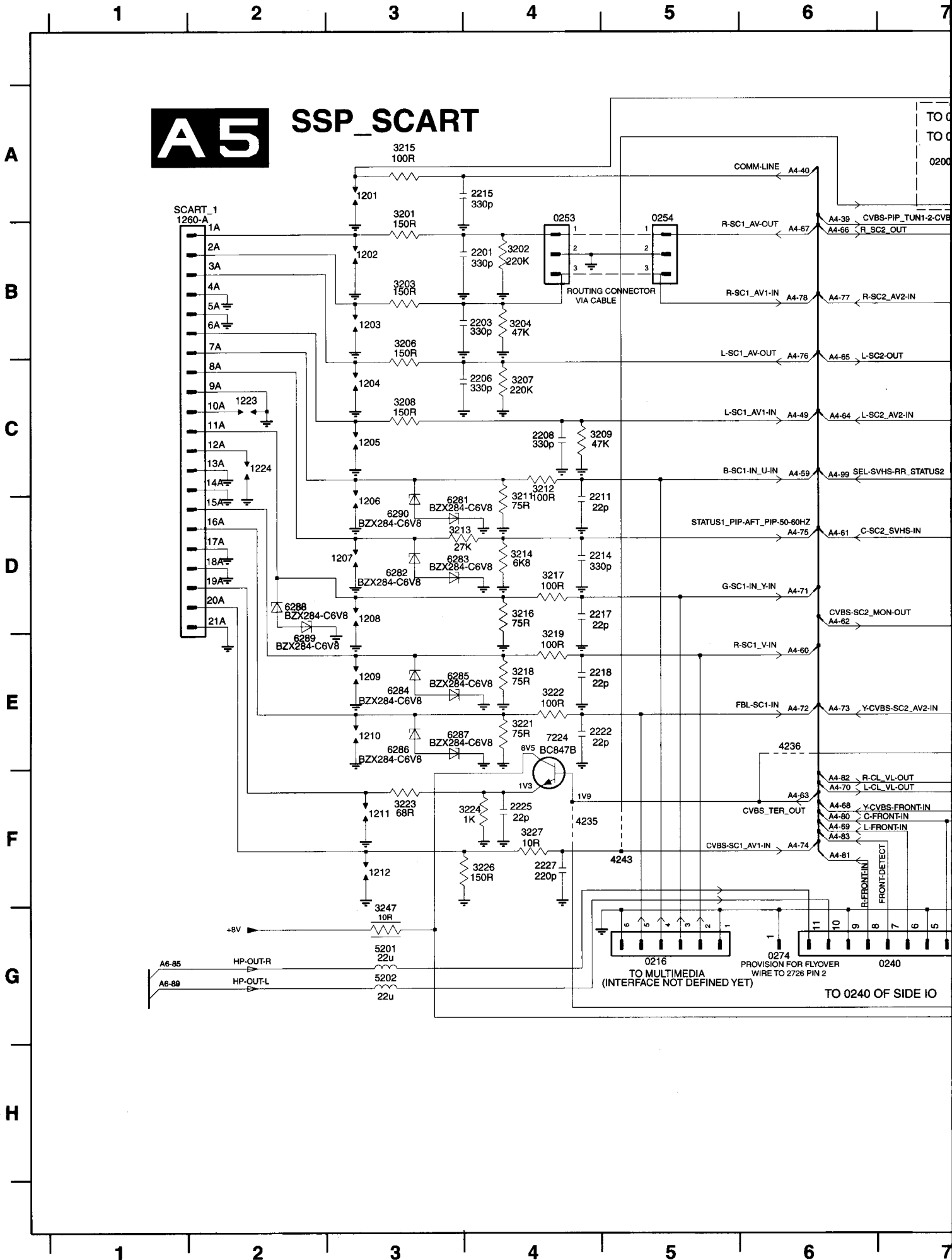

8 9 10 11 12

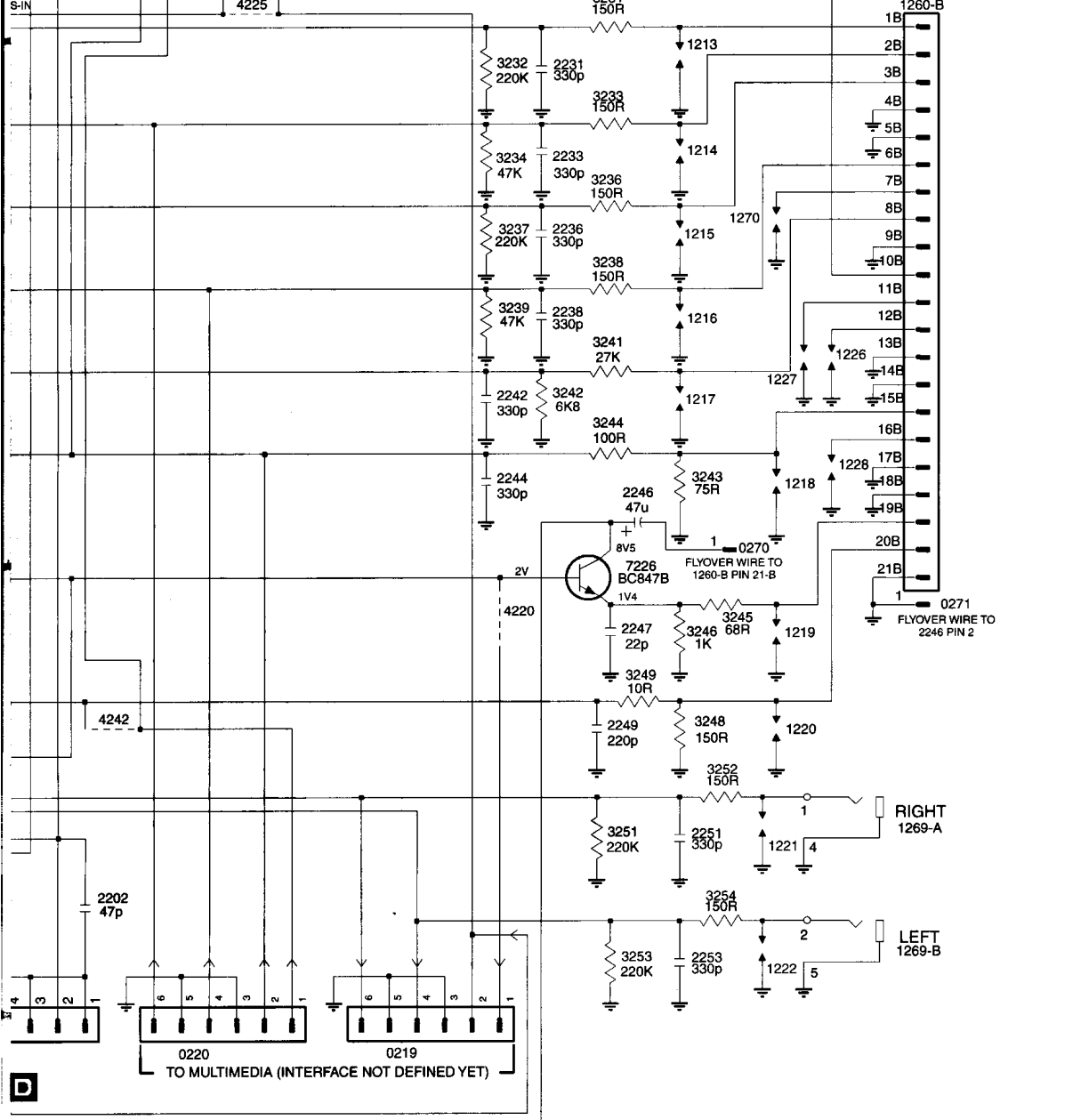
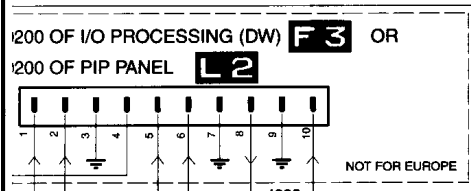

D TO MULTIMEDIA (INTERFACE NOT DEFINED YET)

- 0200 A7
- 0216 G5
- 0219 G9
- 0220 G8
- 0240 G7
- 0253 B4
- 0254 B5
- 0270 D11
- 0271 E12
- 0274 G6
- 1201 A3
- 1202 B3
- 1203 B3
- 1204 C3
- 1205 C3
- 1206 D3
- 1207 D3
- 1208 D3
- 1209 E3
- 1210 E3
- 1211 F3
- 1212 F3
- 1213 B11
- 1214 B11
- 1215 C11
- 1216 C11
- 1217 D11
- 1218 D11
- 1219 E11
- 1220 E11
- 1221 F11
- 1222 G11
- 1223 C2
- 1224 C2
- 1226 C11
- 1227 C11
- 1228 D11
- 1260-A B2
- 1260-B B12
- 1269-A F12
- 1269-B F12
- 1270 C11
- 2201 B4
- 2202 F8
- 2203 B4
- 2206 C4
- 2208 C4
- 2211 D4
- 2214 D4
- 2215 A4
- 2217 D4
- 2218 E4
- 2222 E4
- 2225 F4
- 2227 F4
- 2231 B10
- 2233 B10
- 2236 C10
- 2238 C10
- 2242 D10
- 2244 D10
- 2246 D10
- 2247 E10
- 2249 E10
- 2251 F11
- 2253 F11
- 3201 A3
- 3202 B4
- 3203 B3
- 3204 B4
- 3206 B3
- 3207 C4
- 3208 C3
- 3209 C4
- 3211 D4
- 3212 C4
- 3213 D3
- 3214 D4
- 3215 A3
- 3216 D4
- 3217 D4
- 3218 E4
- 3219 E4
- 3221 E4
- 3222 E4
- 3223 F3
- 3224 F4
- 3226 F4
- 3227 F4
- 3231 A10
- 3232 B10
- 3233 B10
- 3234 B10
- 3236 B10
- 3237 C10
- 3238 C10
- 3239 C10
- 3241 C10
- 3242 D10
- 3243 D11
- 3244 D10
- 3245 E11
- 3246 E11
- 3247 G3
- 3248 E11
- 3249 E10
- 3251 F10
- 3252 E11
- 3253 F10
- 3254 F11
- 4220 E10
- 4225 F4
- 4235 F4
- 4236 E6
- 4242 E8
- 4243 F5
- 5201 G3
- 5202 G3
- 6280 D3
- 6281 D3
- 6282 D3
- 6283 D3
- 6284 E3
- 6285 E3
- 6286 E3
- 6287 E3
- 6288 D2
- 6289 E2
- 7224 E4
- 7226 D10

8 9 10 11 12

Audio

A6 AUDIO

HEADPHONE AMPLIFIER

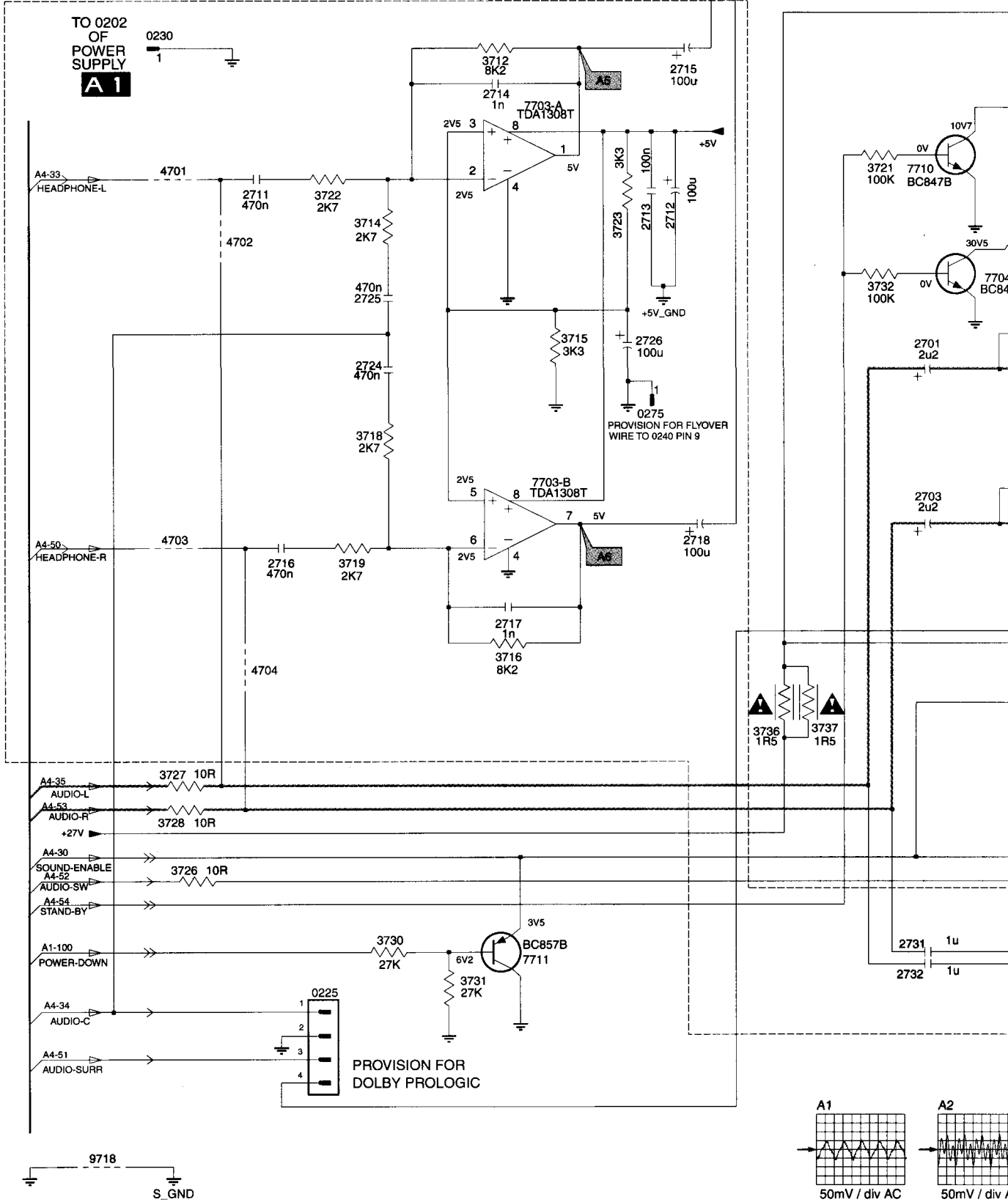

TO 0202 OF POWER SUPPLY
A1

PROVISION FOR FLYOVER WIRE TO 0240 PIN 9

PROVISION FOR DOLBY PROLOGIC

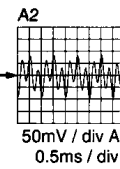
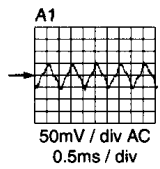

0225 G3
 0230 A2
 0246 D11
 0247 F11
 0275 D5
 2701 C7
 2702 D8
 2703 D7
 2704 D9
 2705 F9
 2706 D11
 2707 D11
 2708 B8
 2709 D10
 2711 B3
 2712 B5
 2713 B5
 2714 B4
 2715 B5
 2716 E3
 2717 E4
 2718 D5
 2719 D8
 2720 E8
 2722 C7
 2723 D7
 2724 C3
 2725 C3
 2726 C5
 2727 D10
 2728 E10
 2729 D9
 2730 E9
 2731 G7
 2732 G7
 2733 G8
 3701 D8
 3702 E8
 3703 G10
 3704 E7
 3705 E8
 3706 E7
 3707 F8
 3708 B8
 3709 B7
 3710 G7
 3711 G7
 3712 B4
 3713 G8
 3714 C3
 3715 C5
 3716 E4
 3717 G9
 3718 D3
 3719 E3
 3720 G9
 3721 B6
 3722 B3
 3723 C5
 3724 C7
 3725 D7
 3726 F2
 3727 F2
 3728 F2
 3730 G4
 3731 G4
 3732 C6
 3733 C7
 3734 D10
 3735 D9
 3736 F6
 3737 F6
 4701 B2
 4702 C3
 4703 D2
 4704 E3
 6701 B8
 7701 E8
 7702 B8
 7703-A B4
 7703-B D4
 7704 C7
 7710 B7
 7711 G4
 7712 G8
 9718 H2

A

B

C

D

E

F

G

H

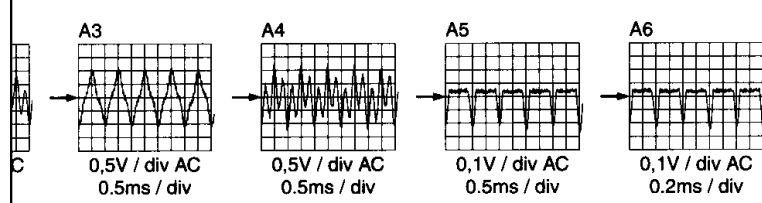
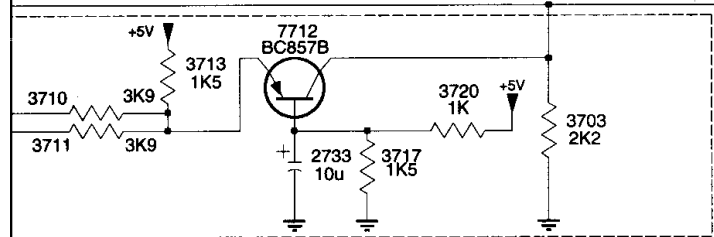
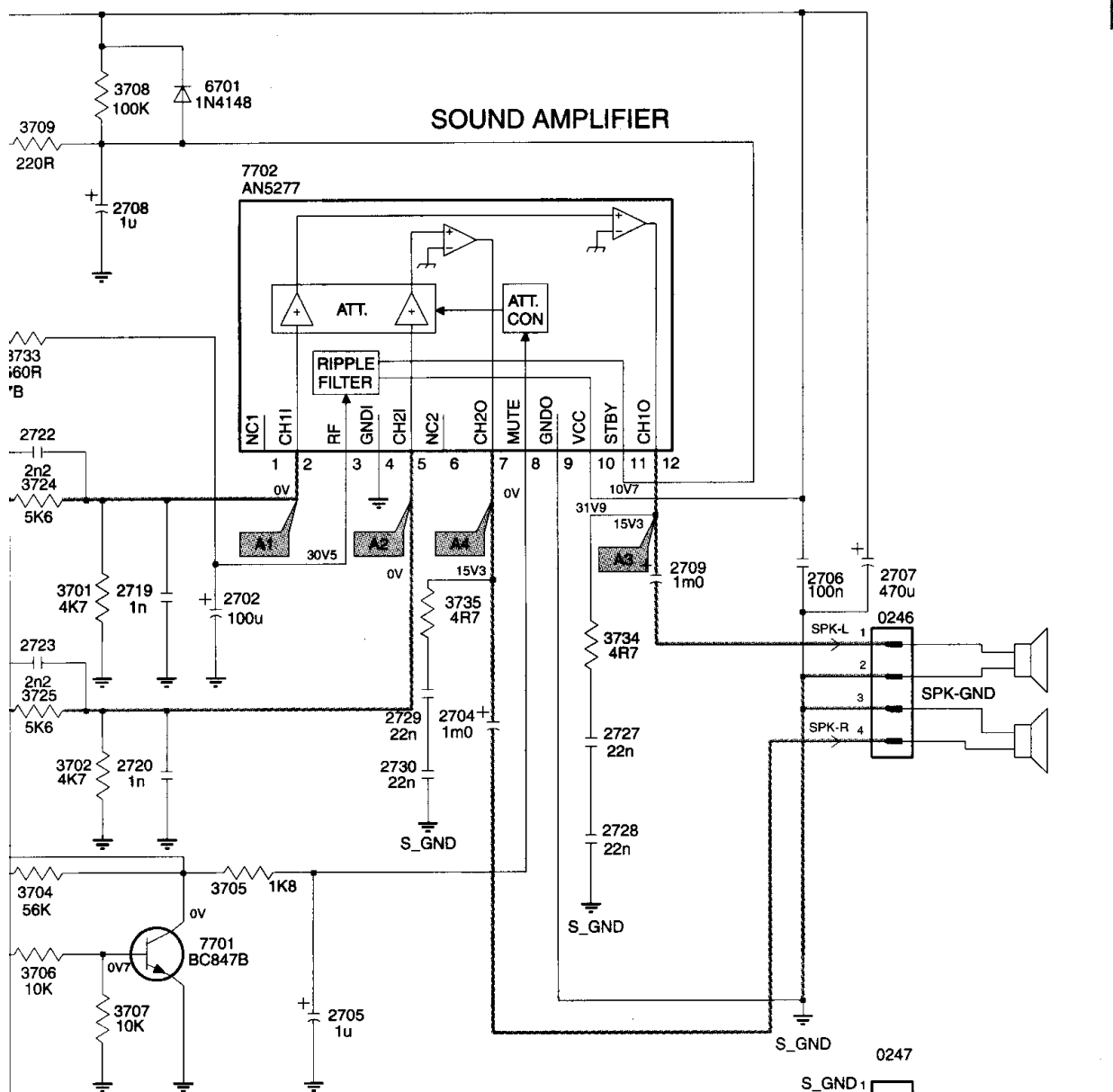
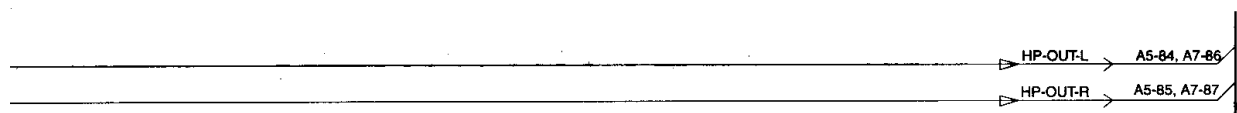

Front control / Rotation / Headphone

A7

FRONT CONTROL / ROTATION / HEAD

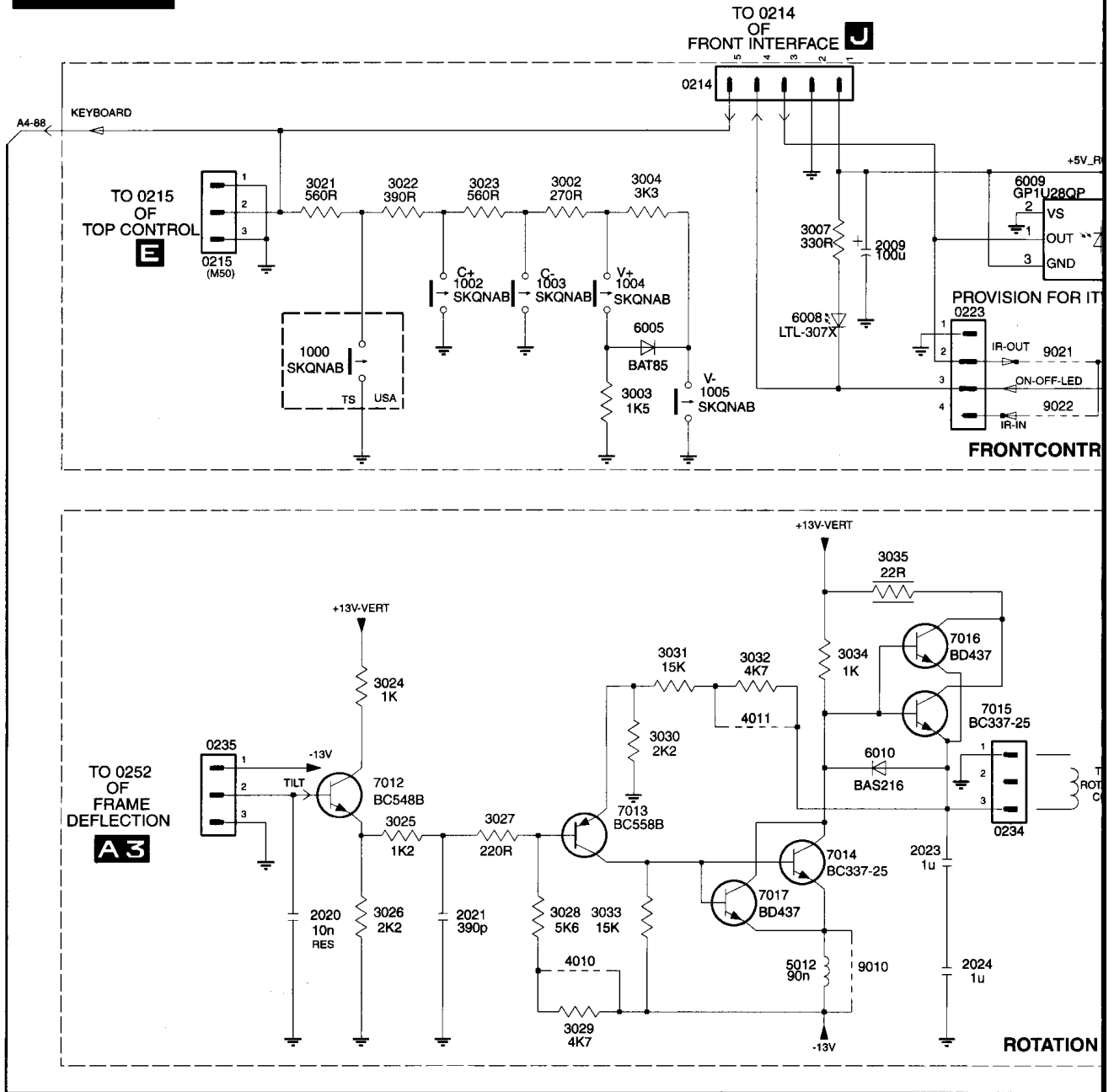

PHONE

STBY
RC5
A4-56
A4-36
DL
D
ATION
DIL

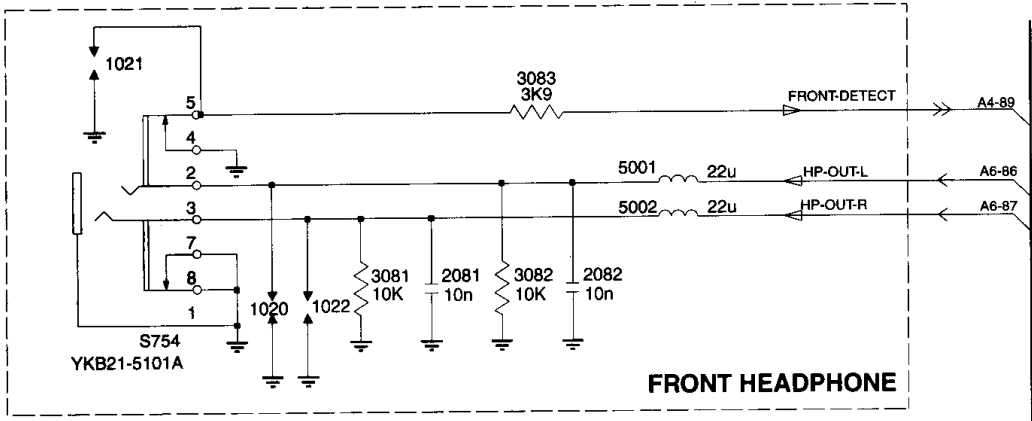

- 0214 B5
- 0215 B2
- 0223 C6
- 0234 E6
- 0235 E2
- 1000 C3
- 1002 C4
- 1003 C4
- 1004 C4
- 1005 C5
- 1020 F9
- 1021 E8
- 1022 F9
- 2009 B6
- 2020 F3
- 2021 F4
- 2023 F6
- 2024 F6
- 2081 F10
- 2082 F10
- 3002 B4
- 3003 C5
- 3004 B5
- 3007 B5
- 3021 B3
- 3022 B3
- 3023 B4
- 3024 E3
- 3025 E3
- 3026 F3
- 3027 E4
- 3028 F4
- 3029 F4
- 3030 E5
- 3031 D5
- 3032 E5
- 3033 F4
- 3034 D6
- 3035 D6
- 3081 F9
- 3082 F10
- 3083 E10
- 4010 F4
- 4011 E5
- 5001 E10
- 5002 F10
- 5012 F5
- 6005 C5
- 6008 C5
- 6009 B7
- 6010 E6
- 7012 E3
- 7013 E4
- 7014 F6
- 7015 E6
- 7016 D6
- 7017 F5
- 9010 F6
- 9021 C7
- 9022 C7
- S754 F9

A
B
C
D
E
F
G
H

CRT panel

1

2

3

4

5

6

7

A

B

C

D

E

F

G

H

B CRT PANEL

TO 0242 LSP (SSP-TUNER) **A4** 0244

TO 0241 LINE DEFLECTION **A2** 0243

0125 MECHPART

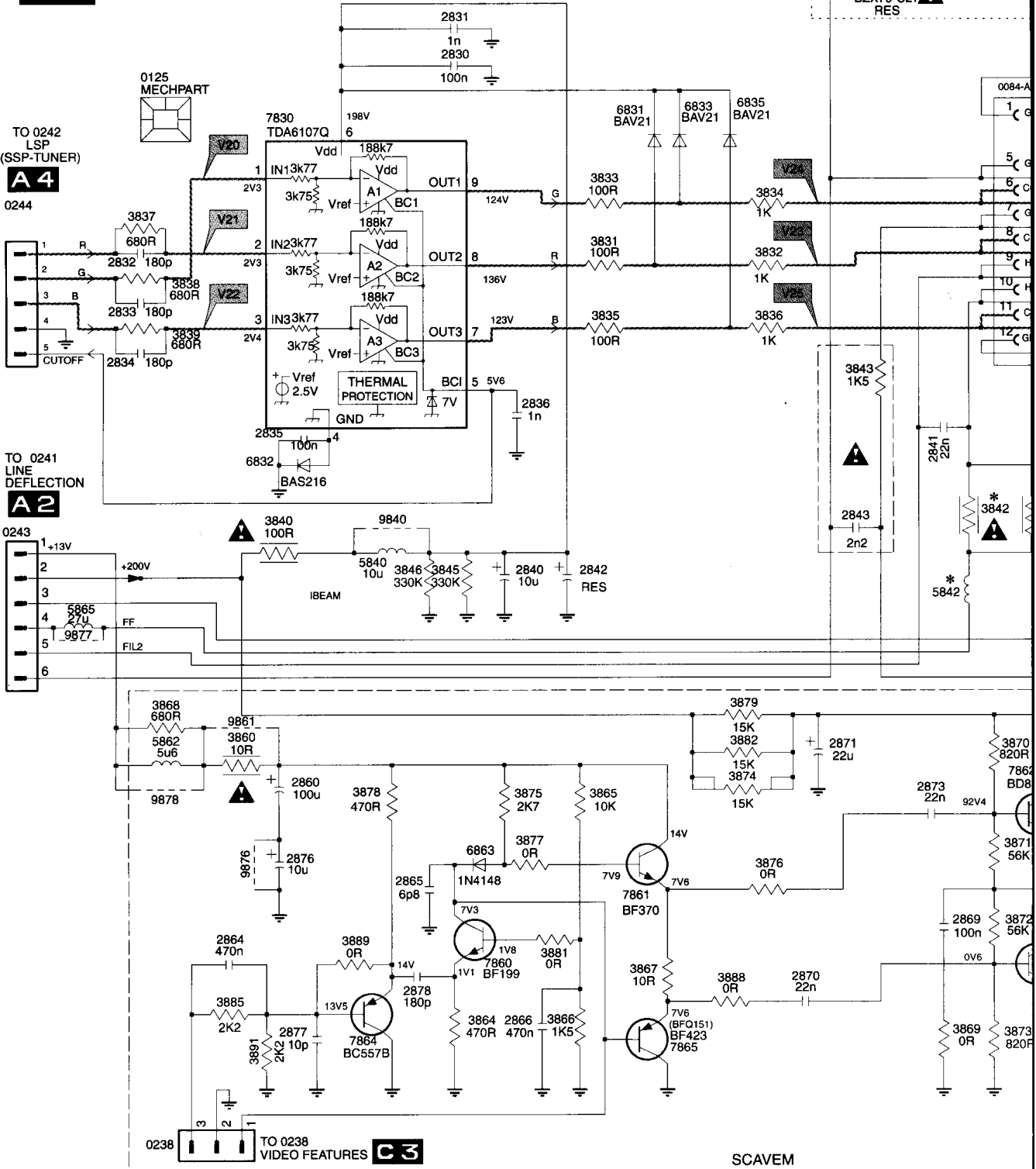

0238 TO 0238 VIDEO FEATURES **C3**

SCAVEM

1

2

3

4

5

6

7

8 9 10 11 12

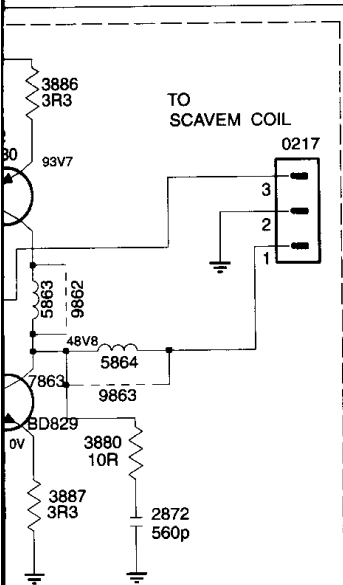
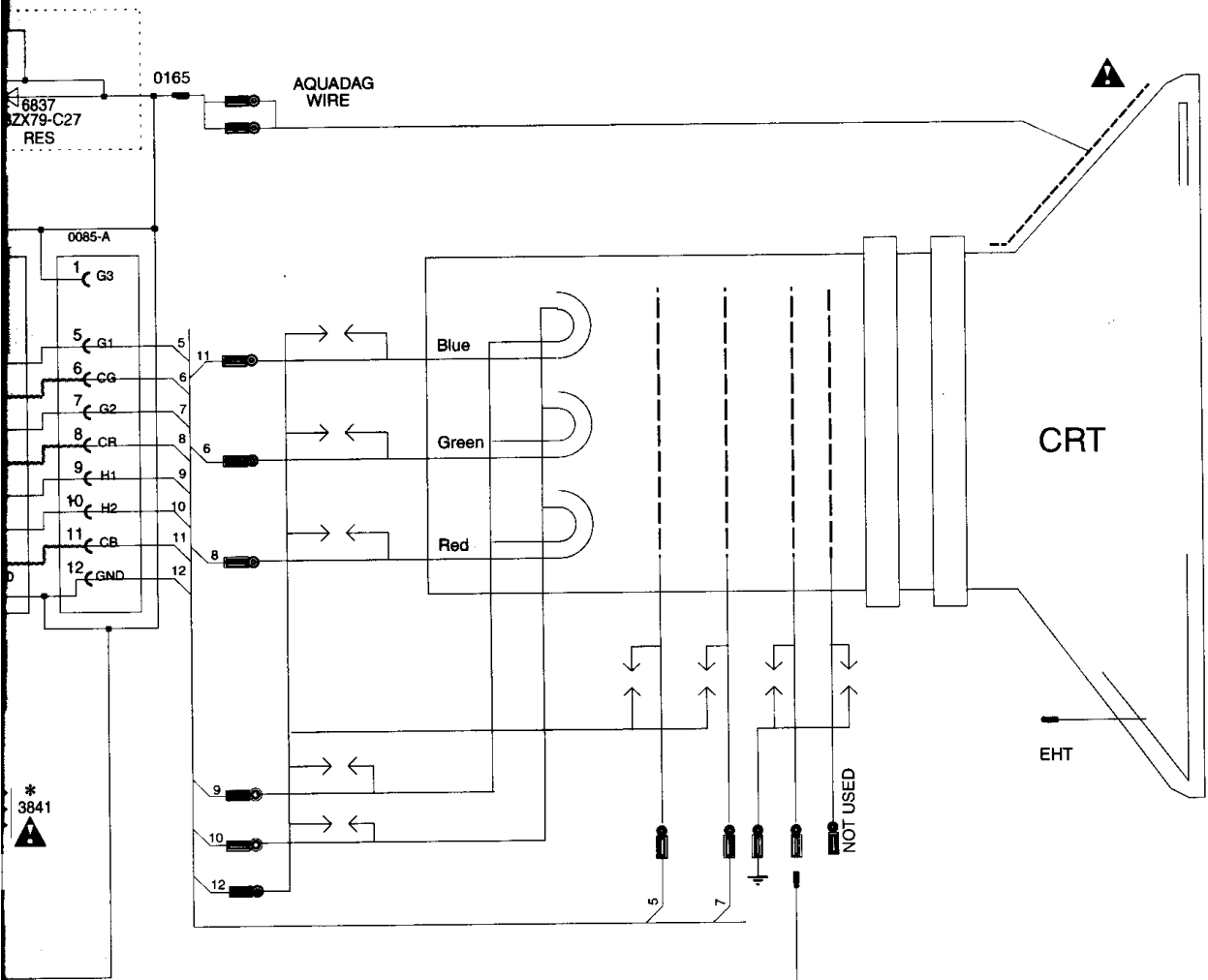

CRT	12 Pin
GND	Pin 1 & 12
VG1	Pin 5
Green	Pin 6
VG2	Pin 7
Red	Pin 8
Heater	Pin 9
Heater	Pin 10
Blue	Pin 11

*	21"	25" BLS	25", 28" BLD	27V	32V	35V	29" SF	FROM LOT A2	
								BLD WIDE 24"/28"	BLS WIDE 28"
5842	47u	47u	33u	56u	82u	18u	56u	47u	56u
3841	1R	1R5	3R3	2R7	1R	1R	1R	1R	1R2
3842	1R	1R5	3R3	2R7	1R	1R	1R	1R	1R2
2838	1N	1N	1N	2N2	2N2	2N2	1N	1N	1N

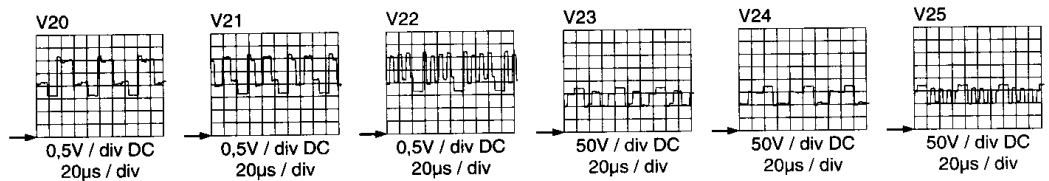

0084-A B7
0085-A B8
0125 B2
0165 A8
0217 F8
0238 H2
0243 D1
0244 B1
0287 E10
2830 A4
2831 A4
2832 C2
2833 C2
2834 C2
2835 D3
2836 C4
2838 A7
2840 D4
2841 D6
2842 D5
2843 D6
2860 F3
2864 F2
2865 F3
2866 G4
2869 F7
2870 G6
2871 E6
2872 G8
2873 F6
2876 F3
2877 G3
2878 G3
3831 B5
3832 C6
3833 B5
3834 B6
3835 C5
3836 C6
3837 B2
3838 C2
3839 C2
3840 D3
3841 D7
3842 D7
3843 C6
3845 D4
3846 D3
3860 E2
3864 G4
3865 F5
3866 G4
3867 G5
3868 E2
3869 G7
3870 E7
3871 F7
3872 F7
3873 G7
3875 F4
3876 F6
3877 F4
3878 F3
3879 E5
3880 G7
3881 G4
3882 F5
3885 G2
3886 E7
3887 G7
3888 G5
3889 F3
3891 G3
3892 A7
5840 D3
5842 D7
5862 E2
5863 F7
5864 F8
5865 E2
6831 B5
6832 D3
6833 B5
6835 B5
6837 A7
6838 A6
6863 F4
7830 B3
7860 G4
7861 F5
7862 E7
7863 G7
7864 G3
7865 G5
9840 D3
9861 E2
9862 F7
9863 G7
9876 F3
9877 E2
9878 F2

8 9 10 11 12

IF & SYNC

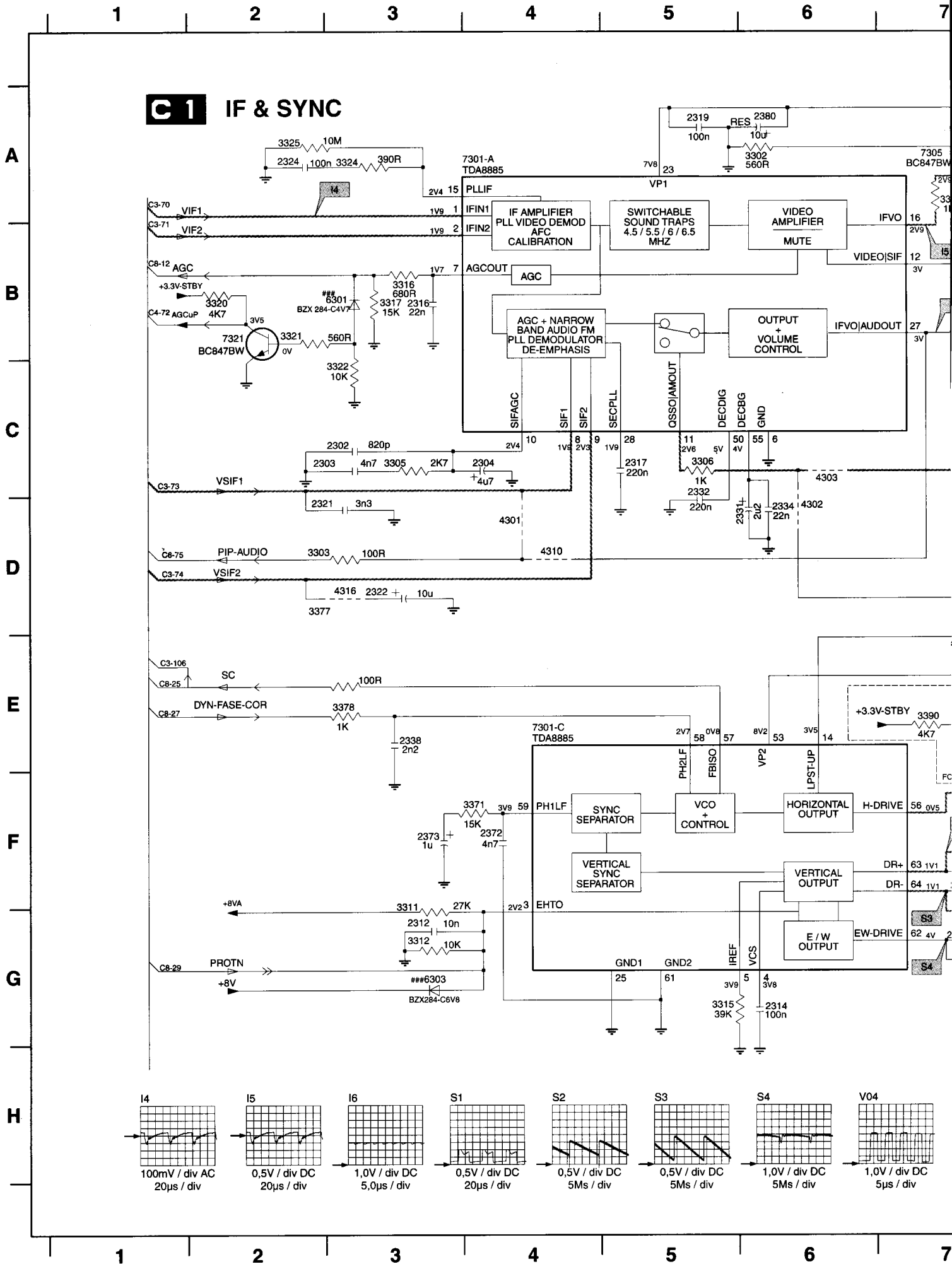

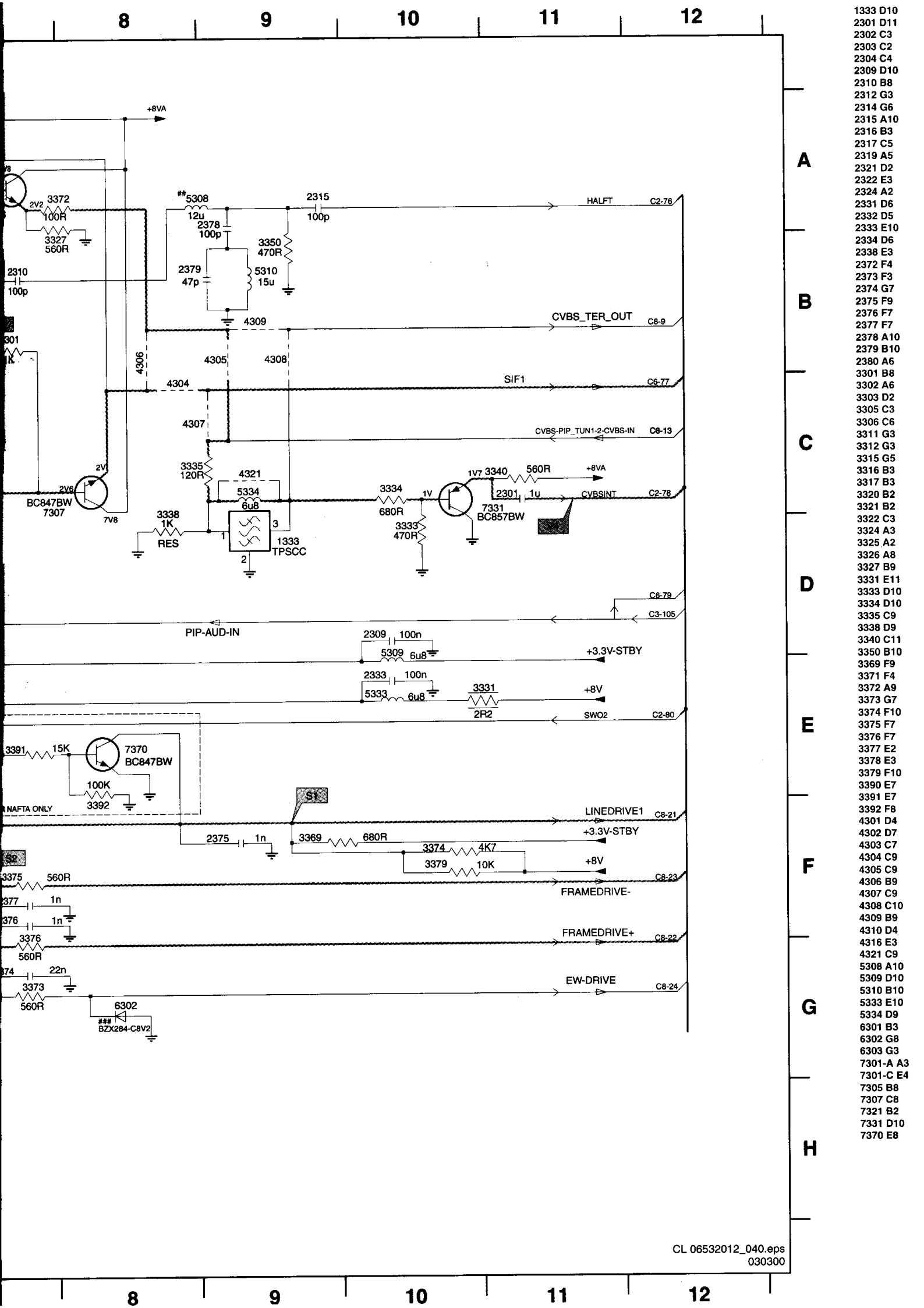

- 1333 D10
- 2301 D11
- 2302 C3
- 2303 C2
- 2304 C4
- 2309 D10
- 2310 B8
- 2312 G3
- 2314 G6
- 2315 A10
- 2316 B3
- 2317 C5
- 2319 A5
- 2321 D2
- 2322 E3
- 2324 A2
- 2331 D6
- 2332 D5
- 2333 E10
- 2334 D6
- 2338 E3
- 2372 F4
- 2373 F3
- 2374 G7
- 2375 F9
- 2376 F7
- 2377 F7
- 2378 A10
- 2379 B10
- 2380 A6
- 3301 B8
- 3302 A6
- 3303 D2
- 3305 C3
- 3306 C6
- 3311 G3
- 3312 G3
- 3315 G5
- 3316 B3
- 3317 B3
- 3320 B2
- 3321 B2
- 3322 C3
- 3324 A3
- 3325 A2
- 3326 A8
- 3327 B9
- 3331 E11
- 3333 D10
- 3334 D10
- 3335 C9
- 3338 D9
- 3340 C11
- 3350 B10
- 3369 F9
- 3371 F4
- 3372 A9
- 3373 G7
- 3374 F10
- 3375 F7
- 3376 F7
- 3377 E2
- 3378 E3
- 3379 F10
- 3390 E7
- 3391 E7
- 3392 F8
- 4301 D4
- 4302 D7
- 4303 C7
- 4304 C9
- 4305 C9
- 4306 B9
- 4307 C9
- 4308 C10
- 4309 B9
- 4310 D4
- 4316 E3
- 4321 C9
- 5308 A10
- 5309 D10
- 5310 B10
- 5333 E10
- 5334 D9
- 6301 B3
- 6302 G8
- 6303 G3
- 7301-A A3
- 7301-C E4
- 7305 B8
- 7307 C8
- 7321 B2
- 7331 D10
- 7370 E8

Video processing

C2 VIDEO PROCESSING

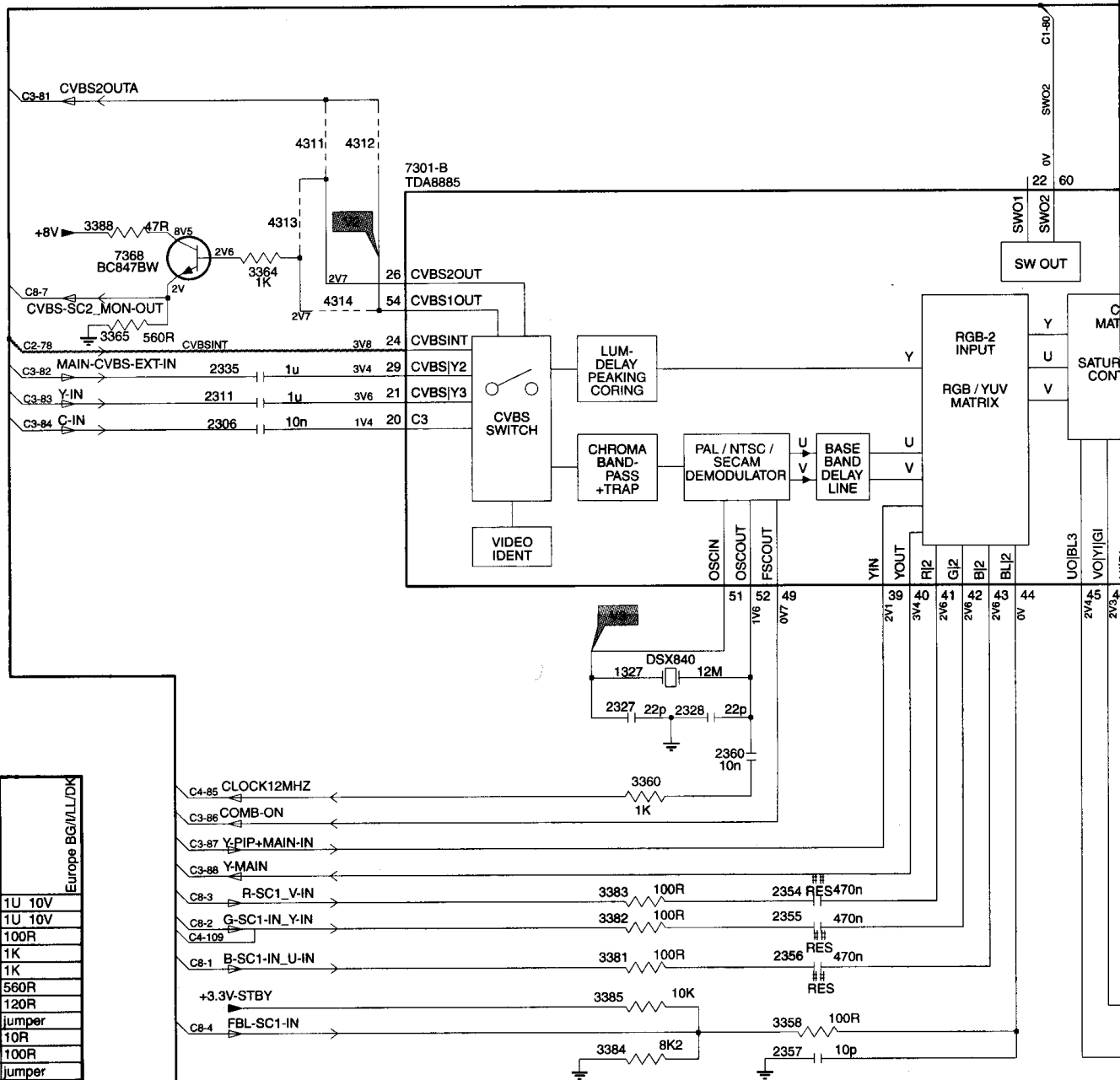

Item	Europe BG/LL/DK
2335	1U 10V
2678	1U 10V
3303	100R
3306	1K
3326	1K
3327	560R
3335	120R
3349	jumper
3372	10R
3373	100R
4303	jumper
4304	jumper
4305	jumper
4308	jumper
4310	jumper
5309	6U8
5334	6U8
7301	TDA 8885
7305	BC847B

A
B
C
D
E
F
G
H

1 2 3 4 5 6 7

1 2 3 4 5 6 7

1327 E5
 2306 D2
 2311 C2
 2313 E8
 2323 F10
 2325 F10
 2326 F10
 2327 E5
 2328 E5
 2335 C2
 2336 C11
 2342 C11
 2343 G10
 2344 G10
 2345 D12
 2348 C11
 2349 D10
 2350 D10
 2354 F5
 2355 F5
 2356 F5
 2357 G5
 2360 E5
 3329 B10
 3330 B10
 3332 E10
 3339 E9
 3341 C10
 3342 G9
 3343 G10
 3344 C10
 3345 G9
 3346 G10
 3348 C10
 3349 D10
 3358 G5
 3360 E3
 3361 F9
 3362 F9
 3363 F9
 3364 C3
 3365 C2
 3381 F4
 3382 F4
 3383 F4
 3384 G4
 3385 G4
 3387 F9
 3388 B2
 3393 E9
 3394 E9
 3395 E10
 3396 E10
 4311 B3
 4312 B3
 4313 B3
 4314 C3
 5332 E10
 6304 D10
 6305 D10
 6306 D11
 6307 F9
 7301-B B3
 7308 E10
 7368 C2

A

B

C

D

E

F

G

H

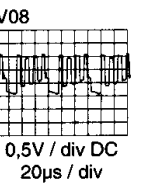
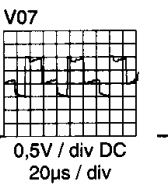
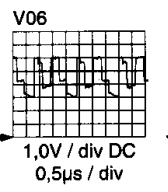
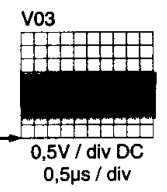
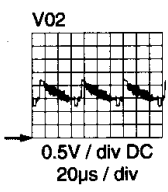
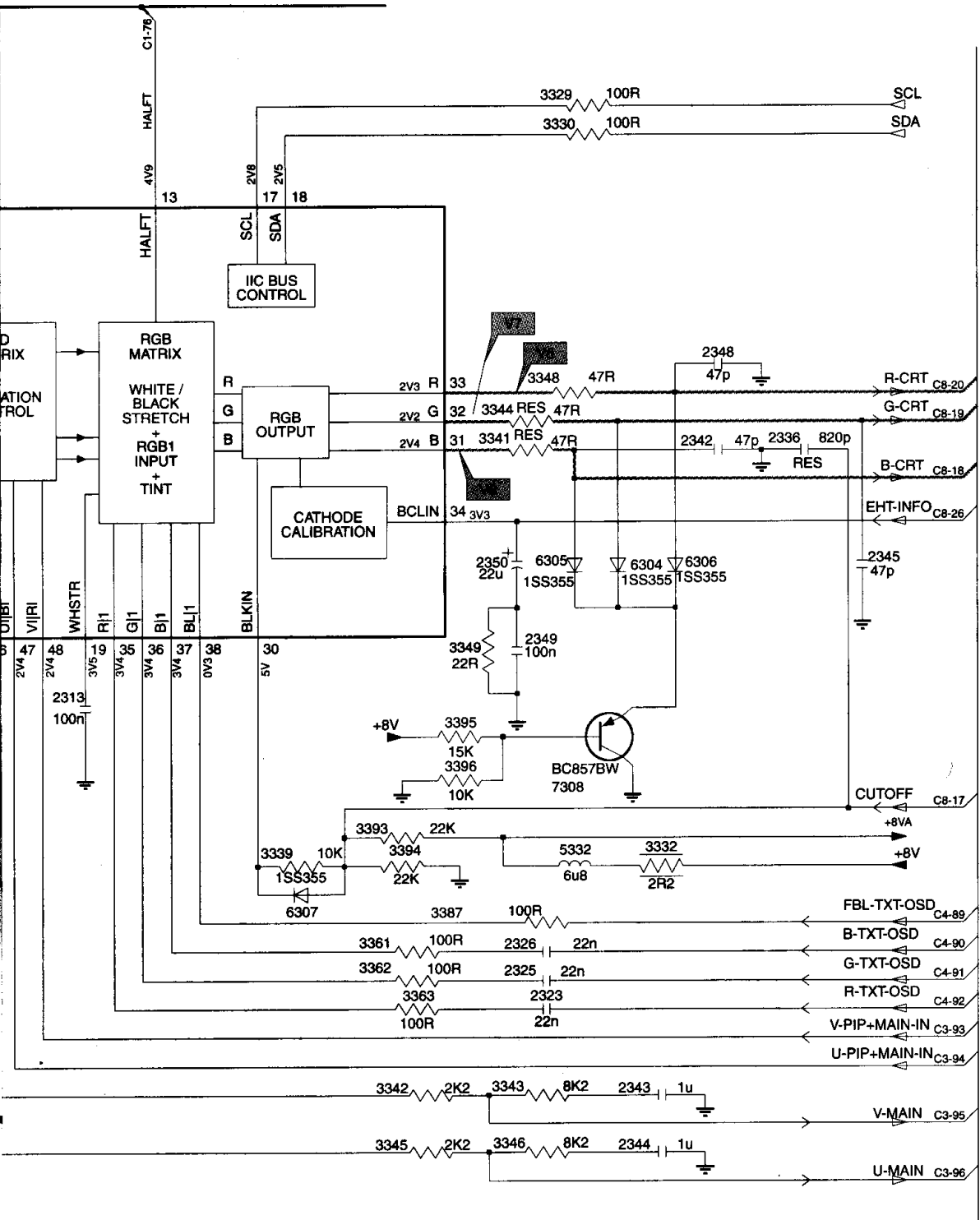

Video features

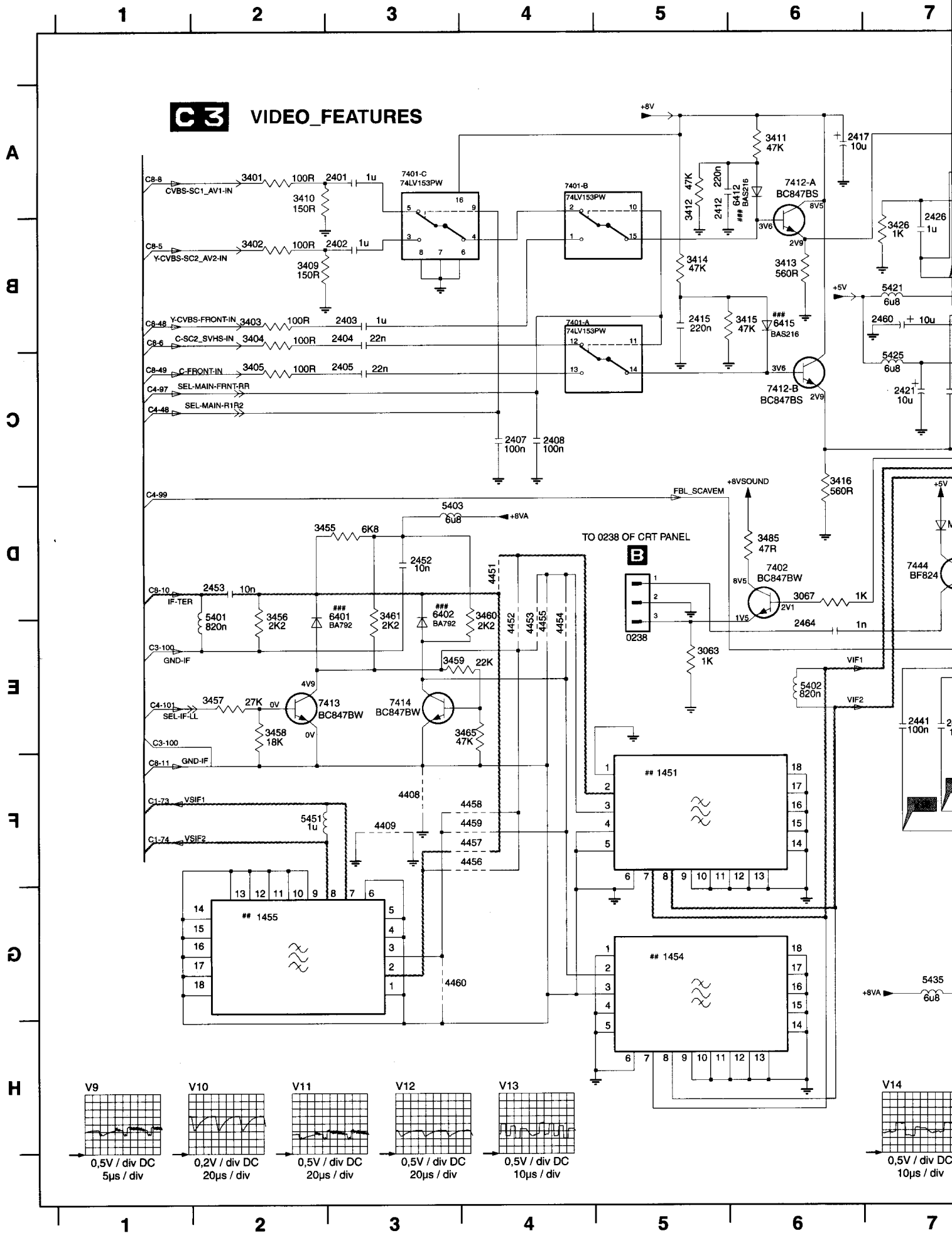

0205 D10	4451 D4
0238 E5	4452 D4
1451 F5	4453 D4
1454 G5	4454 D4
1455 G2	4455 D4
2401 A3	4456 F4
2402 B3	4457 F4
2403 B3	4458 F4
2404 B3	4459 F4
2405 C3	4460 G3
2407 C4	4471 A10
2408 C4	4472 A9
2412 A5	5401 D2
2415 B5	5402 E6
2417 A6	5403 D3
2420 G11	5421 B7
2421 C7	5425 C7
2422 C8	5435 G7
2423 C7	5451 F2
2424 C11	6401 E3
2425 C11	6402 D3
2426 A7	6412 A6
2428 B10	6415 B6
2433 E7	6417 D7
2434 E7	7401 A3
2441 E7	7402 D6
2442 E8	7403 G7
2443 G8	7405 B8
2444 G8	7412-A A6
2445 G8	7412-B C6
2446 G8	7413 E2
2447 G8	7414 E3
2449 G10	7421 A10
2450 G10	7441 F11
2451 G9	7442 E11
2452 D3	7443 G11
2453 D2	7444 D7
2460 B7	7445 D8
2464 E6	
3063 E5	
3067 D6	
3401 A2	
3402 B2	
3403 B2	
3404 B2	
3405 C2	
3406 G12	
3407 G11	
3408 G11	
3409 B2	
3410 A2	
3411 A6	
3412 A5	
3413 B6	
3414 B5	
3415 B6	
3416 C6	
3417 A11	
3418 A11	
3419 C11	
3420 C11	
3423 C8	
3426 B7	
3427 B11	
3428 C9	
3431 E10	
3432 E10	
3435 G10	
3436 G9	
3439 F11	
3440 F11	
3441 F11	
3442 F11	
3443 E8	
3444 E8	
3449 G11	
3452 E9	
3453 E9	
3455 D2	
3456 D2	
3457 E2	
3458 E2	
3459 E3	
3460 D4	
3461 D3	
3465 F4	
3471 D11	
3472 E11	
3473 E11	
3474 E11	
3477 F12	
3480 D7	
3481 D8	
3482 D7	
3485 D6	
4408 F3	
4409 F3	
4431 D10	
4432 E10	
4433 E10	
4434 E10	
4435 E10	
4436 E10	

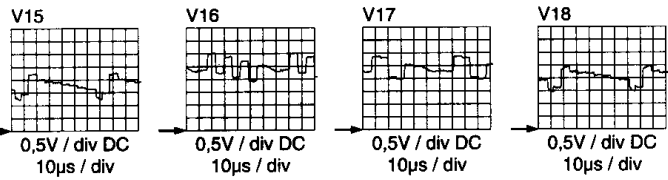
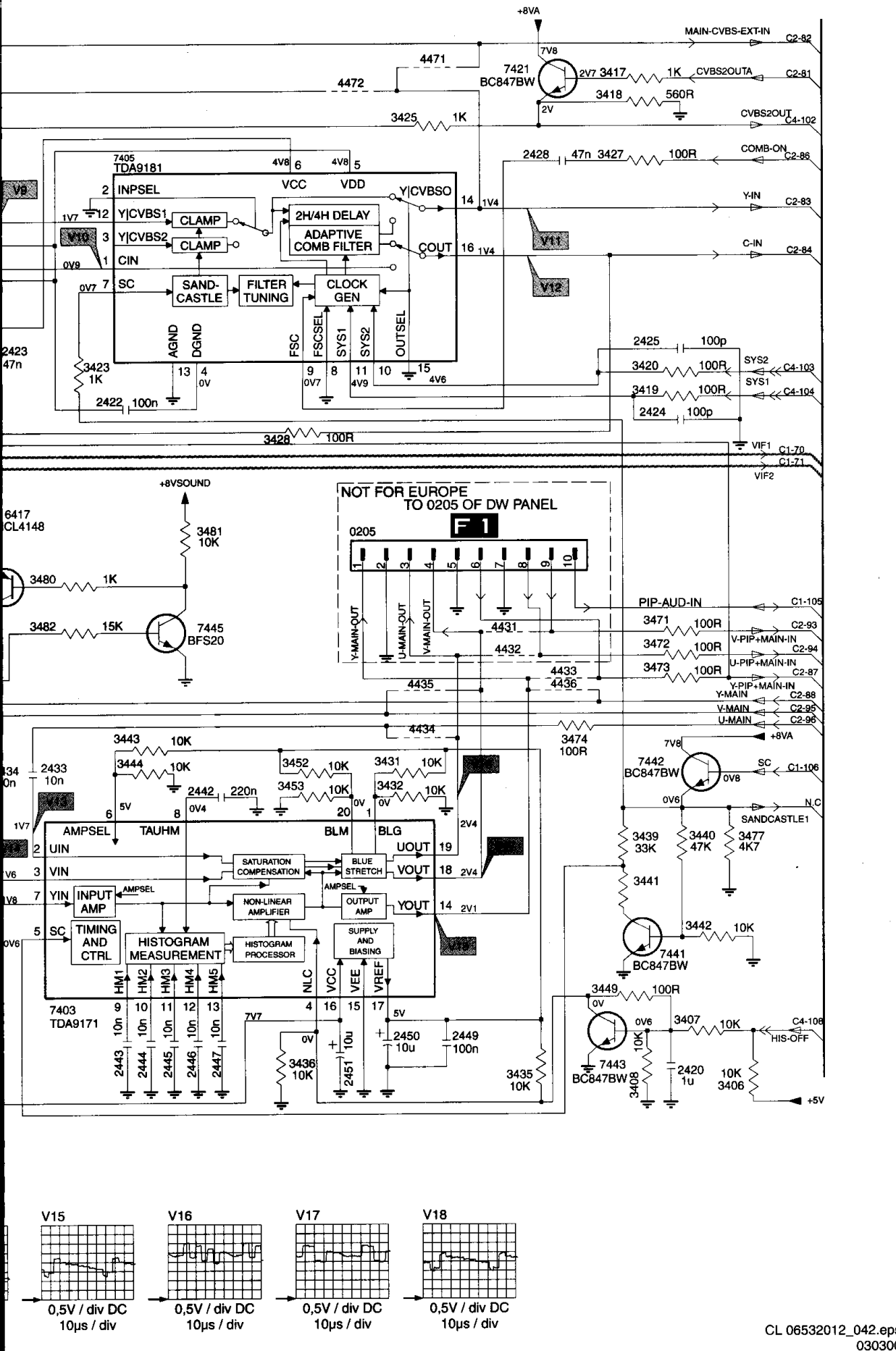

U Cont

1 2 3 4 5 6 7

C4 U_CONT

A B C D E F G H

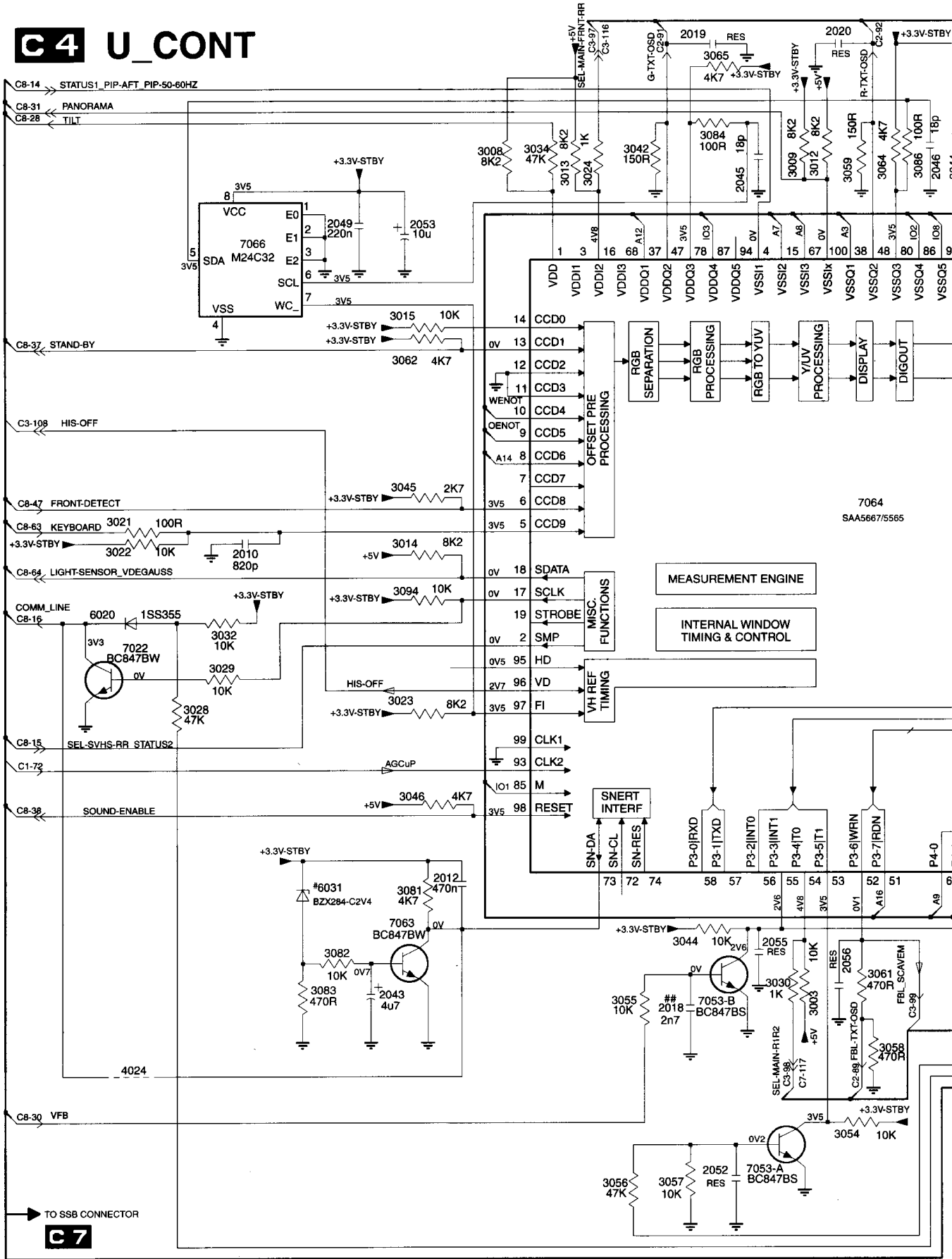

1 2 3 4 5 6 7

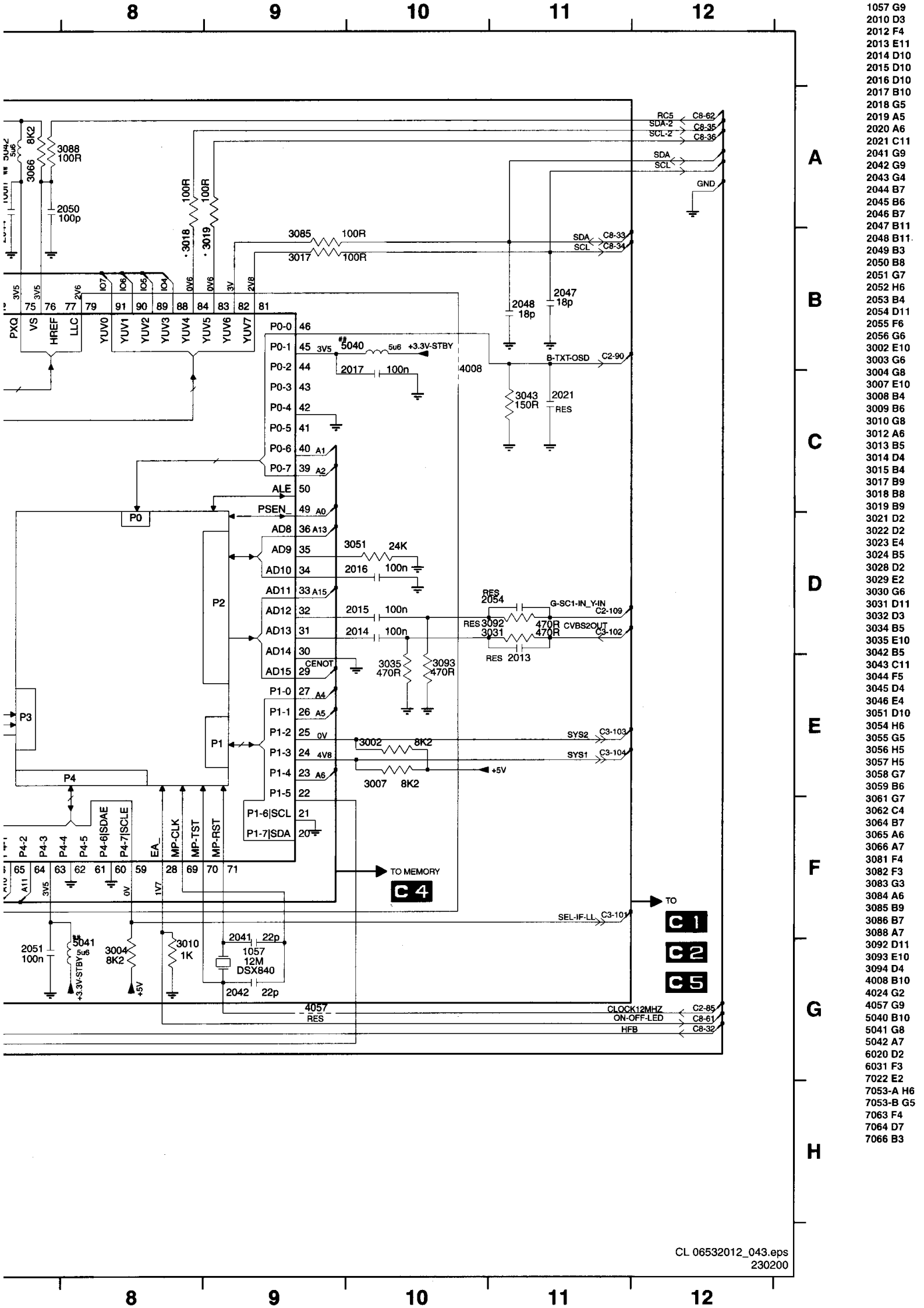

- 1057 G9
- 2010 D3
- 2012 F4
- 2013 E11
- 2014 D10
- 2015 D10
- 2016 D10
- 2017 B10
- 2018 G5
- 2019 A5
- 2020 A6
- 2021 C11
- 2041 G9
- 2042 G9
- 2043 G4
- 2044 B7
- 2045 B6
- 2046 B7
- 2047 B11
- 2048 B11
- 2049 B3
- 2050 B8
- 2051 G7
- 2052 H6
- 2053 B4
- 2054 D11
- 2055 F6
- 2056 G6
- 3002 E10
- 3003 G6
- 3004 G8
- 3007 E10
- 3008 B4
- 3009 B6
- 3010 G8
- 3012 A6
- 3013 B5
- 3014 D4
- 3015 B4
- 3017 B9
- 3018 B8
- 3019 B9
- 3021 D2
- 3022 D2
- 3023 E4
- 3024 B5
- 3028 D2
- 3029 E2
- 3030 G6
- 3031 D11
- 3032 D3
- 3034 B5
- 3035 E10
- 3042 B5
- 3043 C11
- 3044 F5
- 3045 D4
- 3046 E4
- 3051 D10
- 3054 H6
- 3055 G5
- 3056 H5
- 3057 H5
- 3058 G7
- 3059 B6
- 3061 G7
- 3062 C4
- 3064 B7
- 3065 A6
- 3066 A7
- 3081 F4
- 3082 F3
- 3083 G3
- 3084 A6
- 3085 B9
- 3086 B7
- 3088 A7
- 3092 D11
- 3093 E10
- 3094 D4
- 4008 B10
- 4024 G2
- 4057 G9
- 5040 B10
- 5041 G8
- 5042 A7
- 6020 D2
- 6031 F3
- 7022 E2
- 7053-A H6
- 7053-B G5
- 7063 F4
- 7064 D7
- 7066 B3

Audio processing

C6 AUDIO PROCESSING

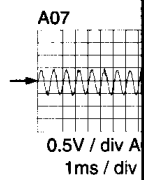
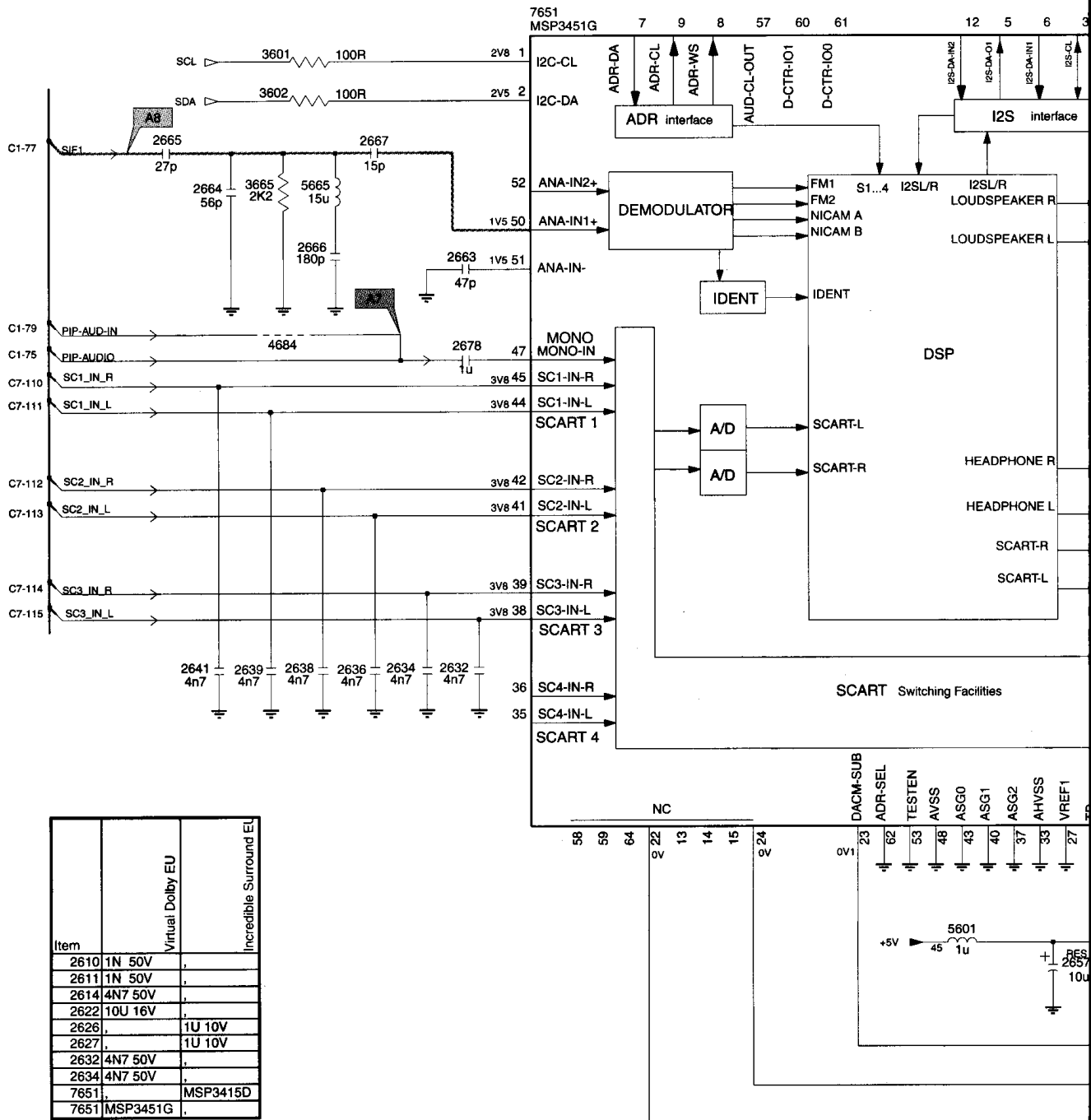

1630 F8
 2601 G7
 2602 G8
 2606 A9
 2607 A9
 2610 B11
 2611 B11
 2612 B11
 2613 B11
 2614 C11
 2616 F9
 2617 E11
 2618 E11
 2619 F10
 2620 E11
 2621 E11
 2622 C9
 2623 C9
 2624 C9
 2625 C10
 2628 C9
 2629 C9
 2632 E4
 2634 E3
 2636 E3
 2638 E3
 2639 E3
 2641 E2
 2655 F10
 2656 F9
 2657 F7
 2661 F8
 2662 C9
 2663 C4
 2664 B2
 2665 B2
 2666 B3
 2667 B3
 2675 F8
 2676 F8
 2678 C4
 2680 C11
 2681 C11
 3601 A3
 3602 B3
 3606 A10
 3616 E10
 3618 E10
 3619 E10
 3621 E10
 3665 B3
 4643 E10
 4644 E9
 4684 C3
 5601 F6
 5625 C10
 5665 B3
 6605 B10
 7651 A4

A

B

C

D

E

F

G

H

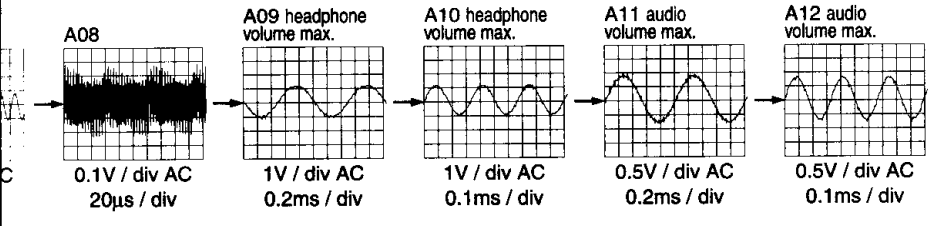
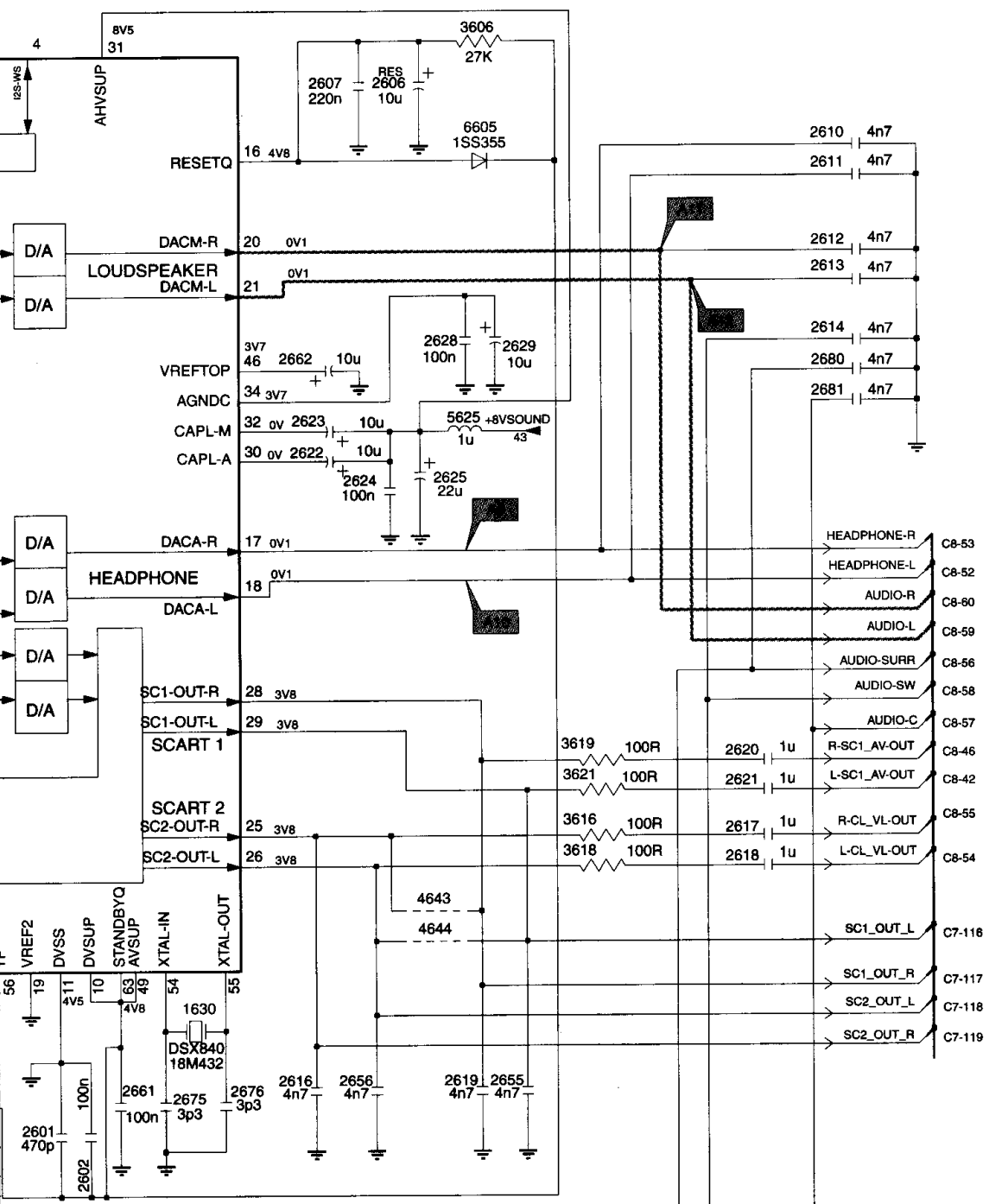

Memory

2058 D2
3090 D2
3091 C6
5050 D2
7070 C3

C5 MEMORY

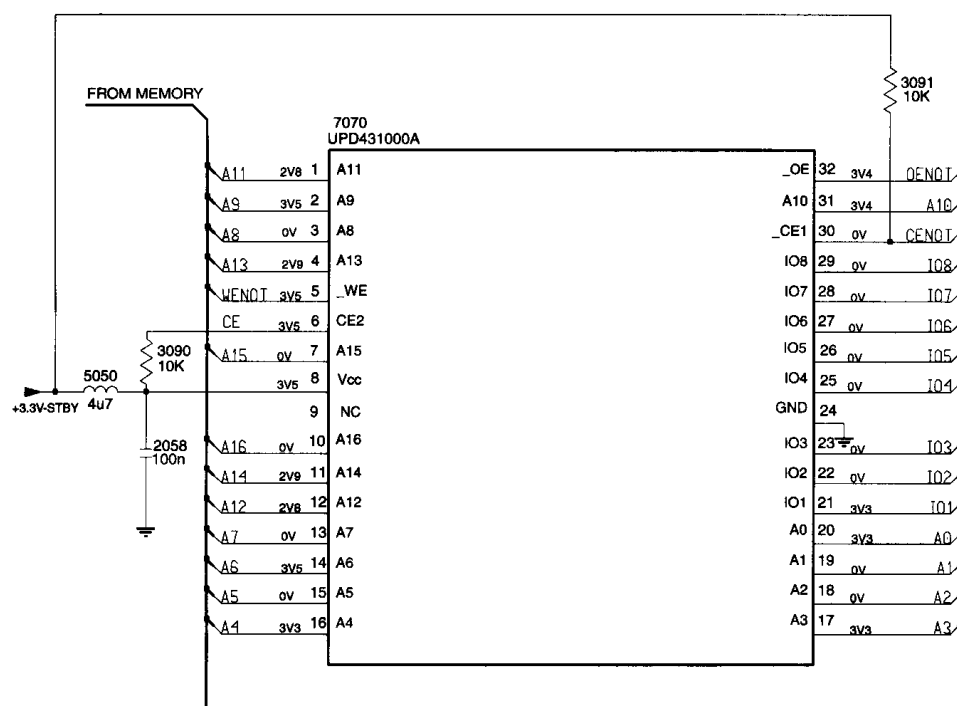

Item	West EU 100Pg Txt	West EU 10Pg Txt	East EU 10Pg Txt	East EU 100Pg Txt
2058	100N 16V			100N 16V
3028	47K			47K
3029	10K			10K
3032	10K			10K
3033	10K			10K
3090	10K			10K
3091	10K			10K
3094	10K			10K
5050	5U6			5U6
6020	1SS355			1SS355
7022	BC847			BC847
7070	UPD431000			UPD431000

C7 AUDIO PROCESSING

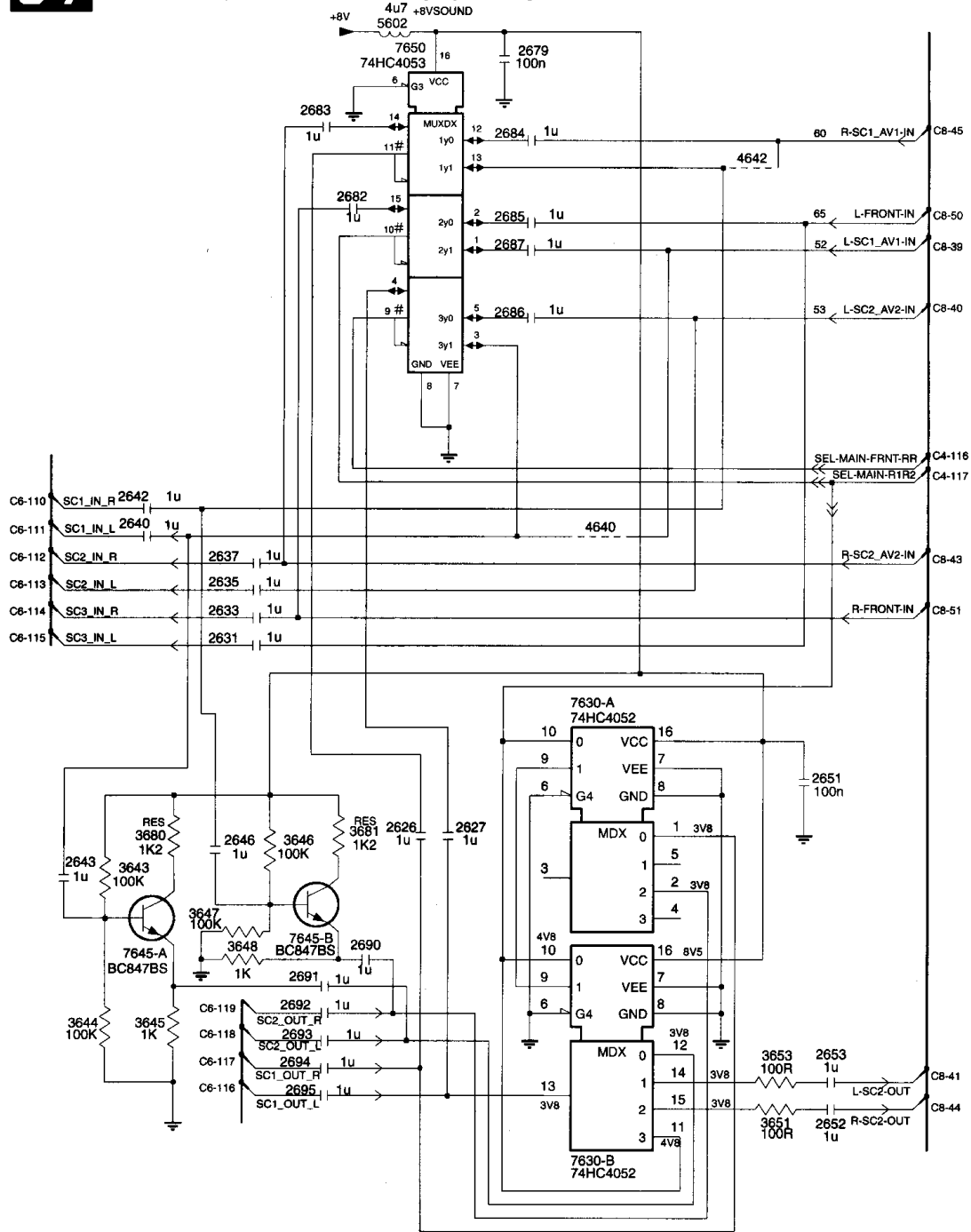

- 2626 E3
- 2627 E3
- 2631 D2
- 2633 D2
- 2635 D2
- 2637 D2
- 2640 D2
- 2642 D2
- 2643 E2
- 2646 E2
- 2651 E5
- 2652 G5
- 2653 F5
- 2679 A4
- 2682 B3
- 2683 A3
- 2684 B4
- 2685 B4
- 2686 B4
- 2687 B4
- 2690 F3
- 2691 F3
- 2692 F3
- 2693 F3
- 2694 F3
- 2695 G3
- 3643 E2
- 3644 F2
- 3645 F2
- 3646 E3
- 3647 F2
- 3648 F2
- 3651 G5
- 3653 F5
- 3680 E2
- 3681 E3
- 4640 D4
- 4642 B5
- 5602 A3
- 7645-A F2
- 7645-B F3
- 7650-A D4
- 7650-B G4

Side I/O



SIDE IO PANEL

0240 A4	1255-C B1	2294 C3	3288 A3	3295 D3	6292 E2	SG04 D1
0241 C4	1256-A A1	2296 E2	3289 B2	3296 E2	6293 E2	SG05 D1
0242 C4	1256-B A1	2297 E3	3291 B2	3297 E3	6294 E2	SG06 E1
1254 D1	2286 A3	3285 A3	3292 B2	4201 A1	SG01 B2	SG07 E1
1255-A D1	2288 A3	3286 A3	3293 C2	4202 A1	SG02 A2	SG08 B1
1255-B C1	2292 B3	3287 A3	3294 C3	6291 E2	SG03 C1	

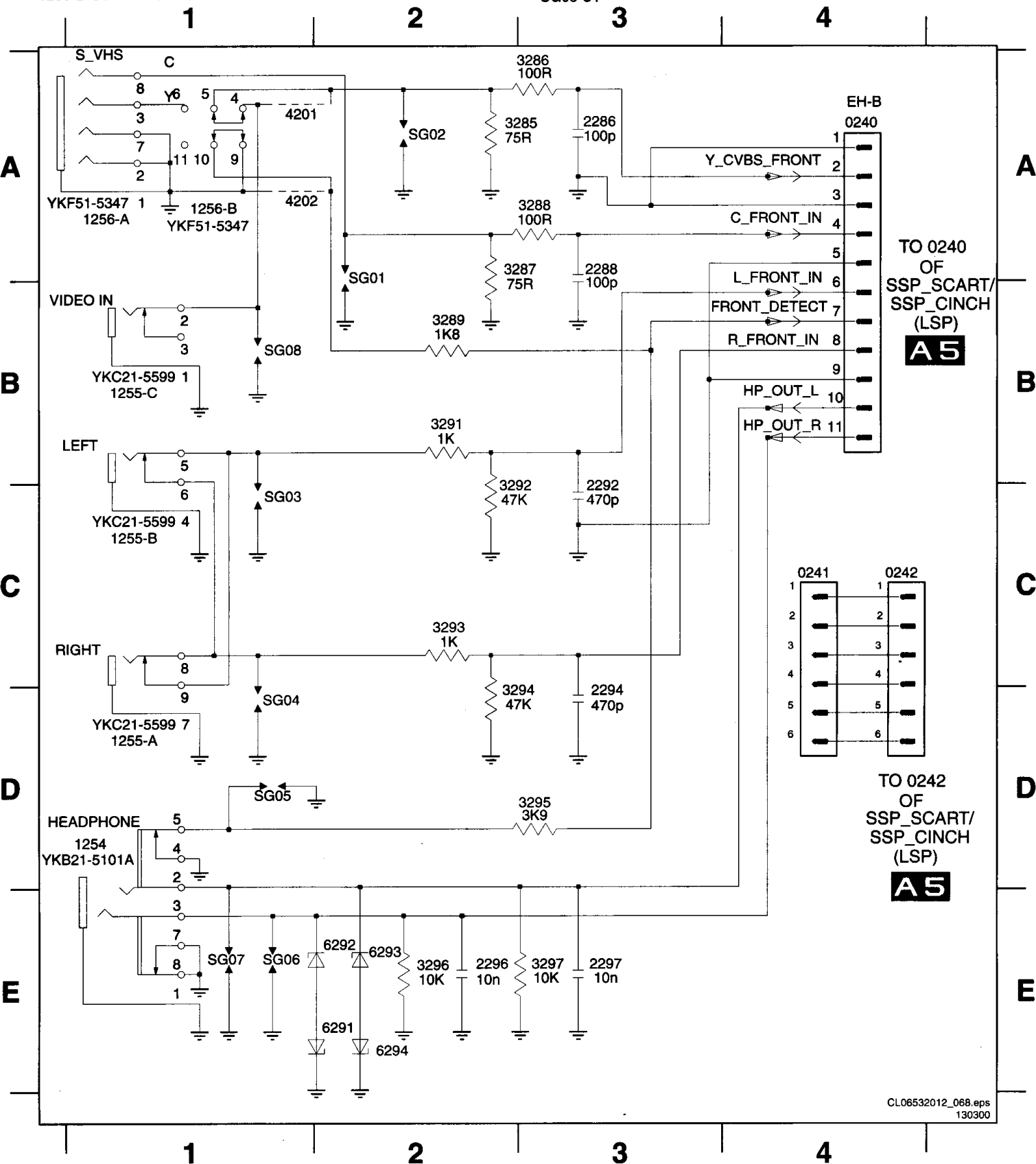

TO 0240
OF
SSP_SCART/
SSP_CINCH
(LSP)
A5

TO 0242
OF
SSP_SCART/
SSP_CINCH
(LSP)
A5